



## Contents

<b>1. Generally</b> .....	<b>2</b>
1.1 Foreword .....	2
1.2 Conditions of guarantee .....	3
1.3 Product identification .....	4
1.4 Information on operating instructions .....	4
<b>2. Construction and function</b> .....	<b>6</b>
2.1 General view .....	6
2.2 Thread running elements .....	7
2.3 Winding heads .....	8
2.4 Drive .....	10
2.5 Electric control system .....	12
2.6 Optional equipment .....	13
2.7 Description of functions .....	14
<b>3. Technical data</b> .....	<b>16</b>
3.1 Dimensions and weight .....	16
3.2 Recommended operating conditions .....	16
3.3 Emissions .....	16
3.4 Compressed air connection .....	17
3.5 Mains connection .....	17
3.6 Drive system .....	17
3.7 Performance characteristics .....	17
<b>4. Safety</b> .....	<b>18</b>
4.1 Purpose of use .....	18
4.2 Danger areas .....	19
4.3 Working safety .....	20
4.4 Requirements of operating personnel .....	20
4.5 Safety equipment .....	20
<b>5. Transport</b> .....	<b>21</b>
5.1 Packing .....	21
5.2 Damage in transit .....	21
5.3 Temporary storage .....	21
<b>6. Start up</b> .....	<b>22</b>
6.1 Setting up .....	22
6.2 Connecting compressed air .....	22
6.3 Connecting electricity .....	23
<b>7. Operating</b> .....	<b>25</b>
7.1 Operating and setting elements .....	25
7.2 Start/stop/cancel winding operation .....	26
7.3 Setting up .....	27
7.4 Machine setting .....	29
7.5 Bobbin sizes .....	38
7.6 Operating instructions .....	38
7.7 Diagnosis .....	41
<b>8. Maintenance</b> .....	<b>60</b>
8.1 Cleaning .....	60
8.2 Lubricating instructions .....	60
8.3 Specification for lubricants .....	60
<b>9. Repair</b> .....	<b>62</b>
9.1 Replacing instrument fuse .....	62
9.2 Pneumatic diagram .....	63
9.3 Wiring diagram .....	64
<b>10. Waste disposal</b> .....	<b>65</b>



# 1. Generally





## 1.1 Foreword

**Dear customer** We congratulate you on your purchase of the newly developed bobbin winding machine **ECCO**. This machine continues our worldwide success with our legendary mechanical bobbin winding machine.

Exceptional reliability and a long service life is guaranteed by:

- the sturdy mechanism, the result of Swiss quality workmanship,
- a comprehensive range of accessories and special tools,
- our after-sales service and spare part service available around the world.

**About our company** Casati Carlo AG has been developing and manufacturing machines and accessories for the textile industry for more than 80 years. Take advantage of our extensive knowhow:

-  Our company's own **training centre** regularly offers training courses for your staff.
-  Our **advisory service** is pleased to help if problems arise with bobbin winding, drawing, punching or embroidering.
-  Our **agency service** can assist you with its sound knowledge of the market when it comes to buying and selling textile machines.
-  Take advantage of our **extensive stock** of accessories and spare parts for the benefit of your embroidery business.

Please contact us by telephone, fax or e-mail for immediate further information:



**Phone:** +41 / 71 744 55 40  
**Fax:** +41 / 71 744 56 24  
**E-mail:** [casati@casati.com](mailto:casati@casati.com)  
**Internet:** <http://www.casati.com>

Casati Carlo AG



## 1.2 Conditions of guarantee

Casati Carlo AG guarantees the proper functioning of the bobbin winding machine with a guarantee of:

 **12 months**, where used in single shift operation  
or

 **6 months**, where used in multiple-shift operation

The guarantee period commences on the date of delivery of the bobbin winding machine from the factory of Casati Carlo AG.

The guarantee covers

- labour costs for repairs,
- all replaceable electric and mechanical parts.

The customer shall be responsible for the costs of:

- shipping and customs clearance for the bobbin winding machine or spare parts,
- travelling expenses and board and lodging for service personnel.

The manufacturer shall not be liable for damage arising from:

- operation not in accordance with the operating instructions,
- non-observance of operation and safety regulations,
- inadequate maintenance,
- production stoppages,
- force majeure.

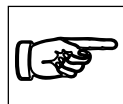

All claims under the guarantee for the bobbin winding machine are void if:

- repairs or modifications are carried out by the customer or third parties without the **manufacturer's written approval**,
- accessories or spare parts of other manufacturers are used,
- the machine is re-sold.



**1.3 Product identification**

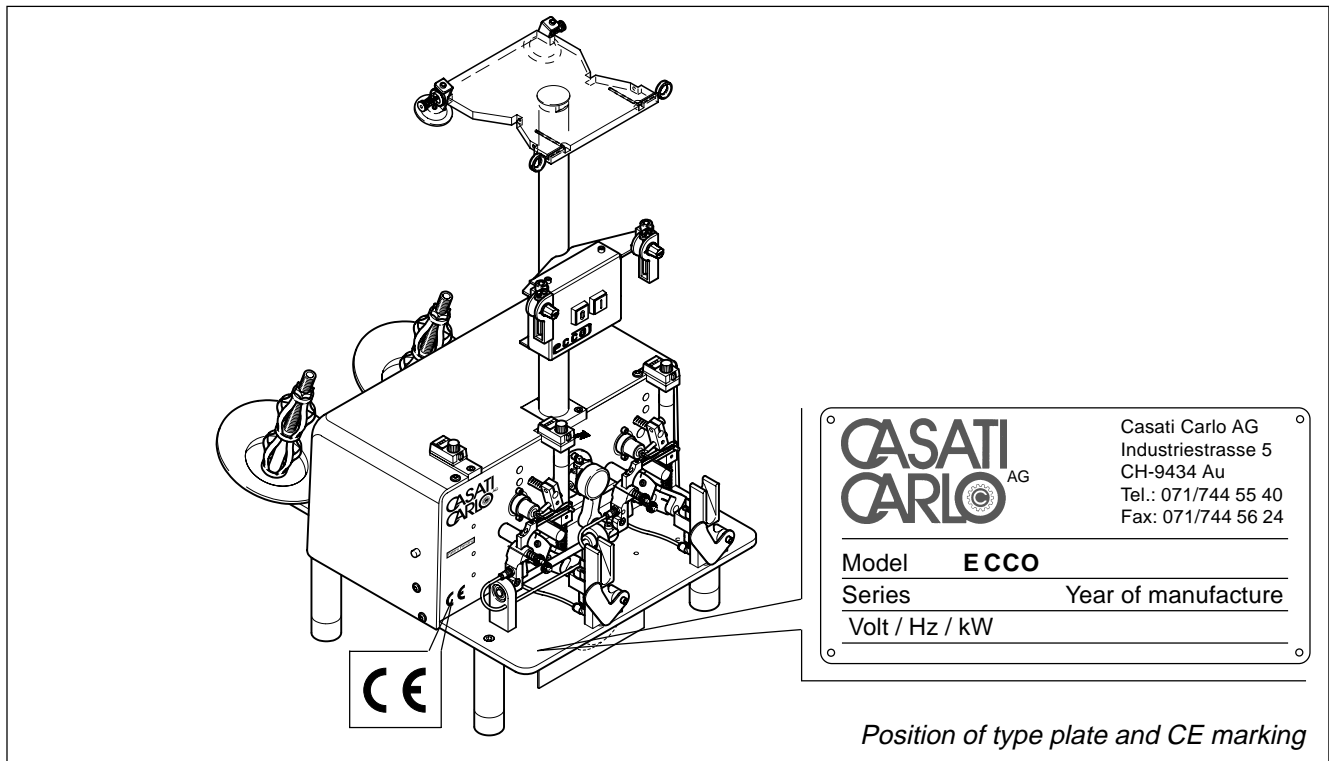

*Position of type plate and CE marking*

**Machine versions** Bobbin winding machine **ECCO** with mechanic/pneumatic control system.

Right-hand drive of bobbin winding machine (standard) or left-hand drive.

The machine specification sheet in index 4 contains detailed information.

**Certification of origin** The bobbin winding machine **ECCO** was designed and manufactured by Casati Carlo AG in Switzerland.

**Level of technology** Modifications made as a result of technical improvements are carried out without any requirement of giving notice. For this reason the illustrations, technical specification and scope of delivery shall not be binding.

**1.4 Information on operating instructions**

**Impress** The present operating instructions have been drawn up in accordance with the EU Directive for machines 98/37/EEC, app. 1, no 1.7.4 „Operating instructions“.  
Edition: March 2000, version 1.0  
Setting and illustrations: Dogrel AG, St Margrethen, Switzerland



**Copyright** These operating instructions may not either wholly or in part be copied, photographed, reproduced, translated or converted into a form which may be read electronically or by machine without the manufacturer's prior written permission.

© Copyright with Casati Carlo AG  
9434 Au, Switzerland  
All rights reserved.

**Safe keeping** These operating instructions should be available to the operating personnel in their entirety and at all times:

 Keep the operating instructions in a place easily accessible in the vicinity of the bobbin winding machine.

 Do not remove individual parts from the operating instructions.

**Training** In addition to the operating instructions, Casati Carlo AG offers a course of training for operation and maintenance in order that the bobbin winding machine's efficiency is exploited to the full and to ensure that it is always ready for operation.

**Symbols used** Please commit the meaning of the following symbols and wording to memory:



**WARNING**

This symbol indicates a dangerous situation which can cause serious physical injury.



**WARNING**

This symbol gives particular notice of the danger of electric voltage which can cause serious physical injury or death due to electric shock.



**WARNING**

This symbol gives particular notice of the danger of being injured by rotating machine parts.



**ATTENTION**

All situations which can cause damage to the machine are indicated by this symbol.

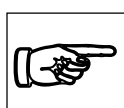

**IMPORTANT**

This sign shows tips on using and useful information.



## 2. Construction and function

### 2.1 General view

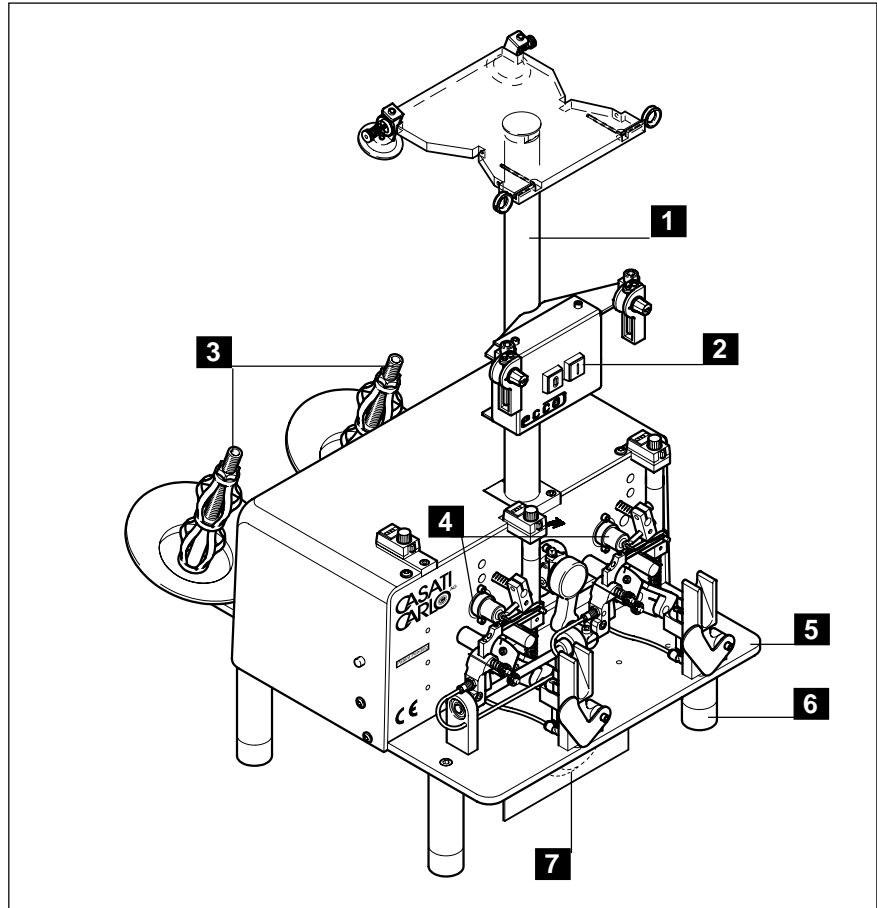

General view

- |                  |                   |
|------------------|-------------------|
| 1 Thread tree    | 5 Base plate      |
| 2 On/Off buttons | 6 Adjustable foot |
| 3 Cone holders   | 7 Electric motor  |
| 4 Winding heads  |                   |

The bobbin winding machine contains two winding heads (4) on the front side. The accompanying cone holders (3) are mounted to the rear of the machine.

The housing of the machine contains the mechanical drive together with the mechanic/pneumatic control system.

On the thread tree (1) the following elements are mounted:

- several thread guiding elements for each winding head,
- the On/Off buttons (2).

To the underside of the base plate four adjustable feet (6) and the electric motor (7) are mounted.

At the rear of the machine the mains socket for the power chord and the compressed air connection can be found.



## 2.2 Thread running elements

Side view

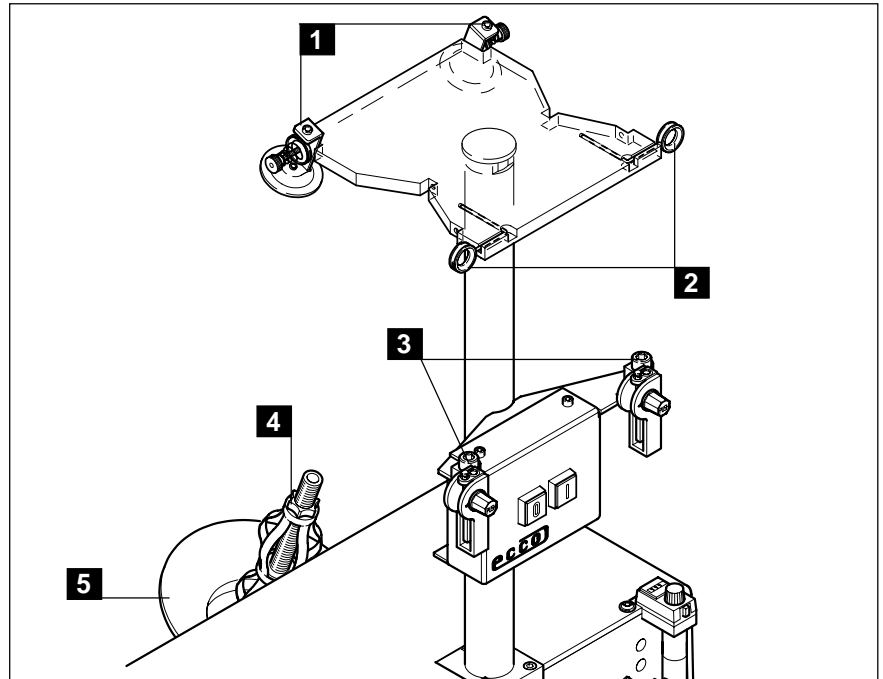

- |                      |                 |
|----------------------|-----------------|
| 1 Inlet brake        | 4 Adjusting nut |
| 2 Thread guiding eye | 5 Cone holder   |
| 3 Compensator        |                 |

The yarn in the form of cones is placed on the two cone holders (5) of the bobbin winding machine.

With the help of the adjusting nuts (4) the cone holders can be adapted to the different sized tubes of the cones. For special cases special adapters must be inserted.

After unwinding on the way to the winding head, the yarn is smoothed and tightened by the inlet brake (1). The inlet brake consists of the thread guiding eyes and two ceramic disks where the yarn passes through. An adjustable spring presses both ceramic disks together and controls the braking effect.

The thread guiding eye (2) is responsible for guiding the yarn to the compensator (3). Using an adjustable swing lever the compensator compensates the jerky movements of the thread guide.



## 2.3 Winding heads

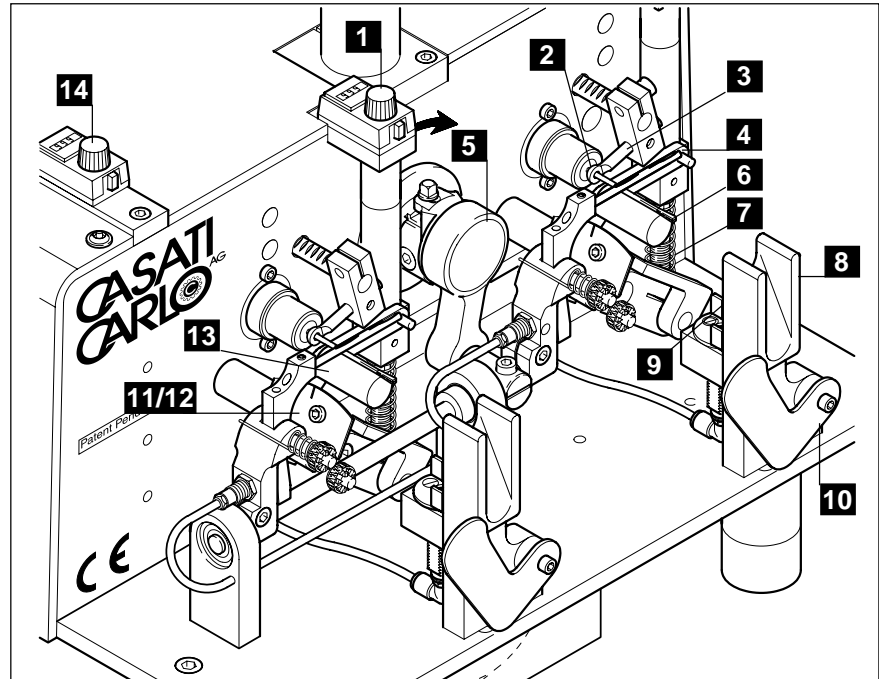

Winding heads on the front side

- |                             |                              |
|-----------------------------|------------------------------|
| 1 Knob for distance setting | 8 Chute                      |
| 2 Chuck                     | 9 Scissors                   |
| 3 Ejector bolt              | 10 Shutter                   |
| 4 Thread guide              | 11 Tucker plate              |
| 5 Eccentric drive           | 12 Undertucker               |
| 6 Spindle                   | 13 Bobbin table              |
| 7 Spring                    | 14 Knob for diameter setting |

The two identical winding heads are arranged on both sides of the eccentric drive.

The two spindles (6)

- are fixed in a chuck (2) and available in different types,
- have the same pre-set direction of rotation,
- rotate at a constant speed during the winding process.

The eccentric drive (5) converts the rotary movement of the main shaft to a to-and-fro motion of the thread guides (4). The motion of the thread guide is adjustable and determines the length of the bobbins.

The ratio of the twisting

- is a result of the movement of the thread guide and the rotation of the spindle,
- is pre-set by toothed gears,
- results in a precise winding.





The bobbin tables (13)

- influence shape and hardness of bobbin,
- are available as sliding or rolling tables,
- are pressed downwards with the increasing thickness of the bobbin.

The distance between the bobbin table and the spindle is adjustable precisely with knob (1).

The adjustable spring (7) determines the contact pressure between the table and the bobbin.

The bobbin diameter at the time of undertucking and ejecting is adjustable with knob (14).

The tucker plate (11)

- swings above the bobbin during undertucking,
- centres the yarn from a slit in the middle of the bobbin.

The undertucker (12)

- is located on the under side of the tucker plate,
- is shaped like a large and small plough blade,
- fixes the yarn to the bobbin during undertucking.

The ejector bolt (3)

- has a borehole in which the spindle rotates,
- slides the undertucked bobbin on to the end of the spindle.

If there is already a bobbin at the end of the spindle, it falls into the chute (8).

The scissors (9)

- are lifted to the chute entry by a pneumatic cylinder,
- cut through the connecting thread to the next following bobbin.

The shutter (10) blocks the chute until the connecting thread is cut. Subsequently, the shutter swings to the side and the finished bobbin falls into the provided collecting container.



2.4 Drive

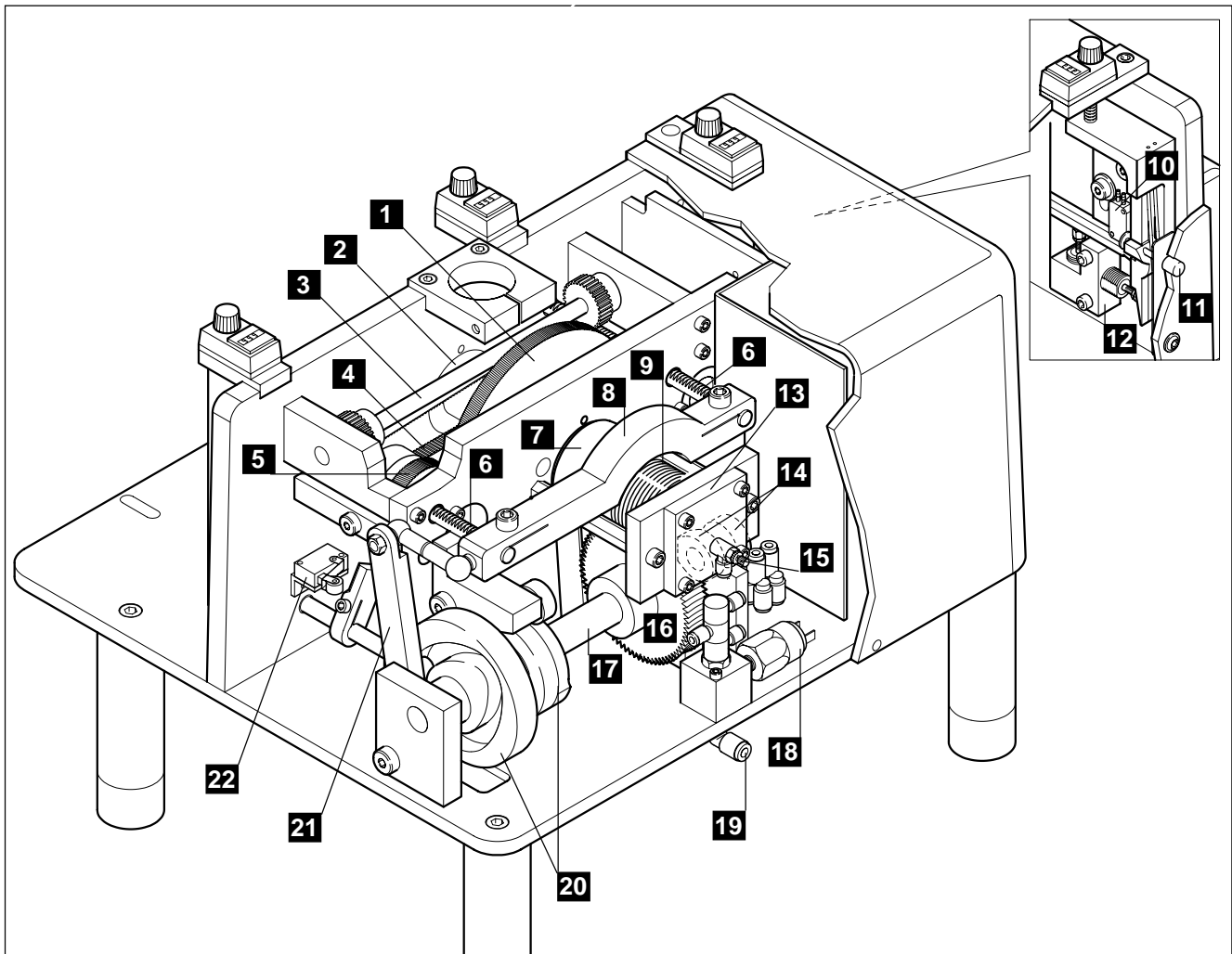

Rear view

- |                                |                                  |
|--------------------------------|----------------------------------|
| 1 Helical gear on main shaft   | 12 Pneumatic cylinder            |
| 2 Main shaft                   | 13 Pneumatically actuated clutch |
| 3 Compensation shaft           | 14 Control cams                  |
| 4 Toothed belt                 | 15 Throttle valve                |
| 5 Cone clutch on spindle shaft | 16 Worm gear                     |
| 6 Gear racks                   | 17 Secondary shaft               |
| 7 Pulley with flat belt        | 18 Manostat                      |
| 8 Yoke                         | 19 Compressed air connection     |
| 9 Worm                         | 20 Large cam plates/disks        |
| 10 Valve                       | 21 Ejector lever                 |
| 11 Reset button                | 22 Roll lever valve              |



The main shaft (2) is connected to the electric motor under the base plate by a belt drive (7). At the front end of the main shaft the eccentric drive for the thread guide and at the rear end of the main shaft a pneumatically activated clutch (13) for driving the secondary shaft (17) is mounted.

The two spindle shafts are connected with a toothed belt (4). One spindle shaft is driven by the main shaft via a helical gear (1). If the cone clutch (5) is disengaged on this spindle shaft both spindle shafts are stopped.

The secondary shaft

- controls the ejection process of bobbins during a full turn,
- is driven by the main shaft via worm (9),
- has an overrun time adjustable on the throttle valve (15) for clutch venting.

The worm is connected to the main shaft frictionally by the clutch (13). The valve for controlling the clutch is activated either by the switch levers of the diameter opening or by the Reset button (11).

The two control cams (14) on the secondary shaft are responsible for

- activating a roll lever valve each,
- determining start and end position of shaft turning,
- lifting and closing the scissors.

When the ejection process is started, the pneumatic cylinder (12) swings the bobbin tables away from the bobbins.

The cam plates/disks (20) on the secondary shaft are

- activating the cone clutch on the spindle shaft via a switching link,
- swinging the tucker plates and shutters,
- activating a roll lever valve (22) for lifting the thread guide from the bobbins,
- moving the ejector bolts.

Both ejector bolts are attached to a yoke (8) via gear racks (6). The yoke is moved by an ejector lever (21). The compensation shaft (3) transfers the movement from the ejector lever to both gear racks and to the ejector bolt.



## 2.5 Electric control system

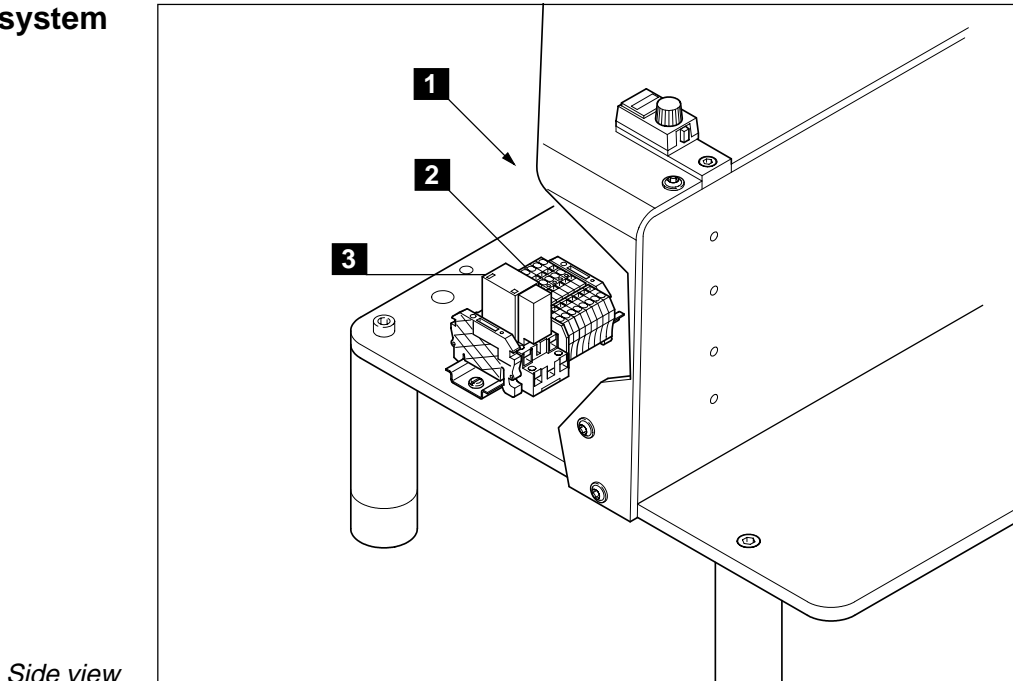

1 Mains socket  
2 Terminal block

3 Control relay

The operating pressure of the compressed air and the motor temperature is monitored by the electric control system via pressure switch and temperature switch.

The mains socket (1) contains fuses for mains connection.

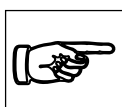

Find more information about replacing fuses under section 9.1 "Replacing instrument fuses".

The control relay (3) switches off the bobbin winding machine or avoids switching on with On/Off switch in case of

- missing or too low operating pressure,
- overheating of electric motor as a result of overload or failure.



## 2.6 Optional equipment

### Oiling device

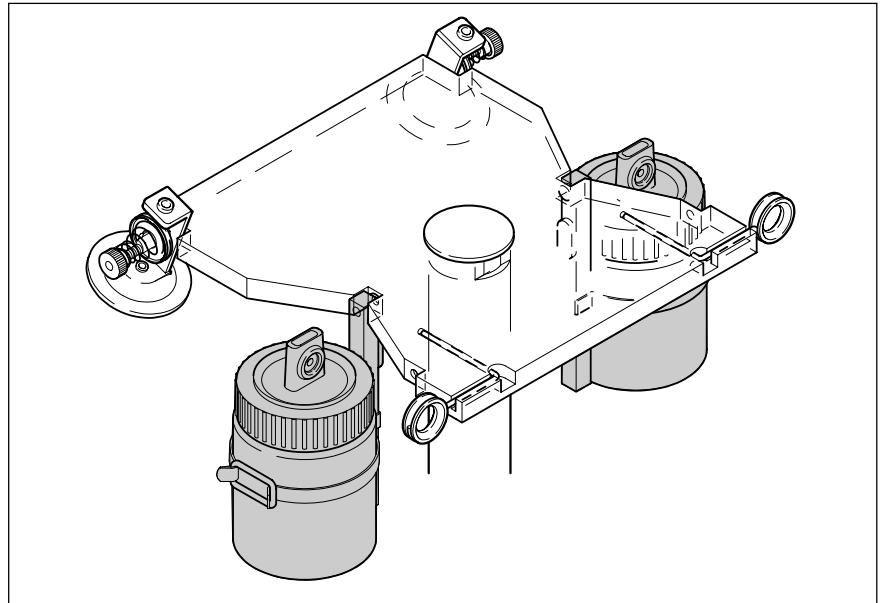

*Oiling devices at the thread tree*

#### The oiling device

- is mounted to the perspex plate,
- is capillary-driven and guarantees an evenly applied coat of oil with a sufficient dosing capacity.

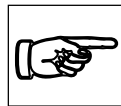

The anti-friction property of the yarn is improved by oiling. The type of oil and the dosage must be determined empirically. The oil wetting can be checked using a precision balance.

### Working tables

When operating several bobbin winding machines robust working tables are required.

Please contact the specialists of Casati Carlo AG.

### Regulation kit

For machine settings a special regulation kit is available (see register 3).



## 2.7 Description of functions

The bobbin winding machine has two winding heads which carry out the following operating cycle:

1. The winding procedure
2. Undertucking the bobbin
3. Ejecting the bobbin
4. Preparing a fresh bobbin winding
5. Cutting the connecting thread to the ejected bobbin.

### Thread guiding

The thread guide is identical for both winding heads. The yarn passes from the cone holders to the thread guiding elements on the perspex plate.

There the yarn

- is tightened by the inlet brake,
- surface-coated by an optional oiling device,
- smoothed within a compensator.

### Winding process

The yarn passes from the compensator to the thread guide. This is driven by an eccentric and moves to and fro above the spindle. The travel of the thread guide can be adjusted on the eccentric and determines the length of the bobbin.

The spindle:

- rotates at a constant speed,
- draws the yarn off from the cone,
- winds a bobbin precisely, corresponding with the movement of the thread guide.

The first layers of thread contract together on the spindle towards the centre and determine the form (curvature) of the bobbin. During the winding process, the diameter of the bobbin increases steadily and presses the bobbin table downwards. The bobbin table influences the hardness, thickness and form of the bobbin.

The bobbin tables

- can be adjusted together to the bobbin diameter,
- can be adjusted separately for pressing force and distance to spindles during start of winding.

If one of the two bobbins has reached the preset diameter the clutch is activated and the secondary shaft is started by the diameter opening.



Simultaneously with activation of the clutch a pneumatic cylinder lifts the bobbin tables from the bobbin. During one turn the secondary shaft is responsible for the following cycles at the winding heads:

**Undertucking the bobbins**

On undertucking

- the thread guides are lifted by pneumatic cylinders,
- the tucker plates swing over the bobbins,
- the chutes are closed by the shutters.

The yarn which is being moved to and fro by the thread guide, slips into the slot in the tucker plate and is wound up with a few turns around the centre of the bobbin.

The undertucker on the under side of the collar plate

- binds the yarn each time under the previous wind,
- fixes the final wind and prevents the bobbin unravelling.

**Ejecting the bobbins**

During the ejection procedure

- the spindles are stopped,
- the ejection bolts are pushing the bobbins of both winding heads to the end of the spindle.

These bobbins remain at the end of the spindles until falling into the chutes during the ejection process of the following bobbins.

**Cutting off the connecting threads**

One pneumatic cylinder lifts and closes each pair of scissors. By doing so, the connecting threads between the bobbins in the chutes and the bobbins at the end of the spindles are severed. Subsequently, the shutters of the chutes are opened and the bobbins produced fall into the collecting container.

**Preparing new bobbins**

During release of clutch and reset of bobbin tables the diameter opening is set to its basic position. Subsequently, the thread guides are swung above the spindles. The spindles start rotating and the yarn guided by the tucker plates is winded several times on top of each other in order to fix it. Subsequently, the tucker plates swing back into initial position.



### 3. Technical data

#### 3.1 Dimensions and weight

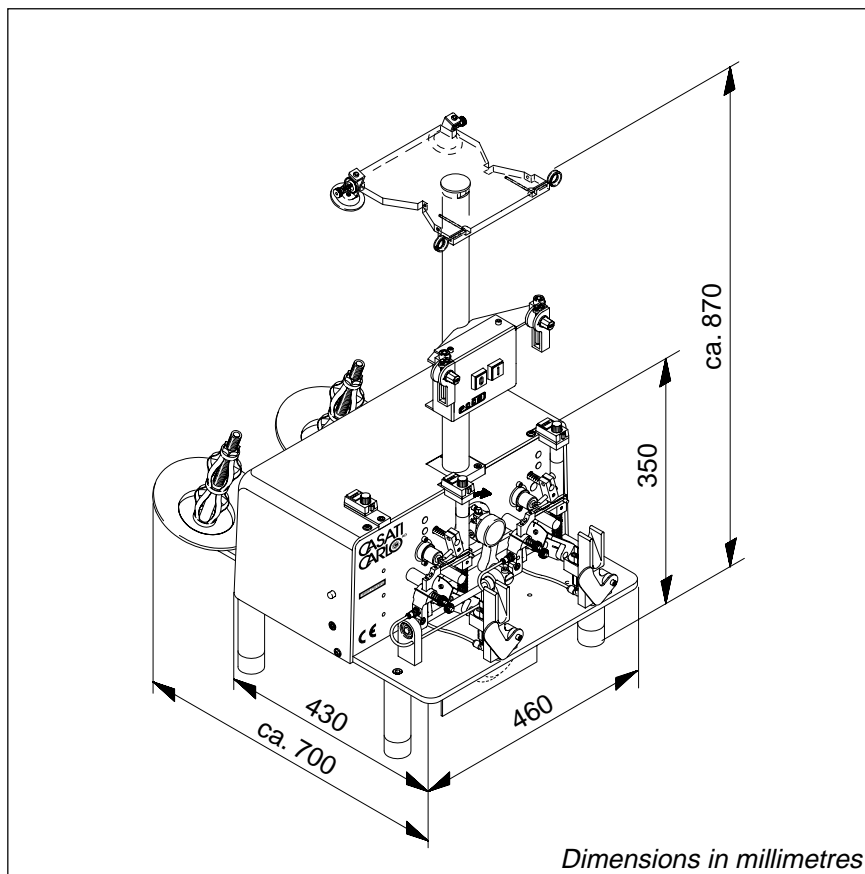

*Bobbin winding machine dimensions*

*Dimensions in millimetres*

L x W x H ..... 460 x 470 x 950 mm

Machine weight ..... 38 kg

Transport weight (incl. packaging) ..... 52 kg

#### 3.2 Recommended operating conditions

Ambient temperature ..... 18°C - 30°C

Relative air humidity (non-condensing) ..... 45% - 65%

Temperature for storage ..... 5°C - 45°C

#### 3.3 Emissions

Continuous sound pressure level at place of work... 65 dB(A)

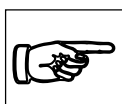

When processing short-staple yarns an increased dust exposure occurs.





**3.4 Compressed air connection**

Type ..... plug-in connection,  $\varnothing$  8 mm  
Operating pressure ..... 5-6 bar  
Air consumption ..... approx. 2-4 dm<sup>3</sup>/h  
Air quality ..... filtered (particle size 0.3  $\mu$ m),  
oil and condensate-free

**3.5 Mains connection**

Standard:  
Mains voltage ..... 1 x 230 V  $\pm$ 10%  
Mains frequency ..... 50 Hz  
Power consumption... ..... ca. 180 W  
Other mains voltages and mains frequency 60Hz are optional.

**3.6 Drive system**

Electric motor ..... 180 W  
Working speed ..... 1600 U/min

**3.7 Performance characteristics**

Suitable yarns ..... different cotton and synthetic yarns  
Maximum size of cones ..... height 300 mm,  $\varnothing$  250 mm  
Size of bobbin ..... max.  $\varnothing$  16,5 x 47 mm  
Shuttle ..... all known sizes may be used  
Bobbin winding ..... precise wind with 8-fold separation  
Capacity ..... approx. 0.25kg bobbins per hour  
(of 80/2 cotton yarn)



## 4. Safety

### 4.1 Purpose of use

**Intended use** The bobbin winding machine **ECCO** may only be used for producing wound packages (bobbins) of natural or synthetic threads within the specified technical data of chapter 3.







**Non-intended use** Any other or excessive use shall be deemed to be a **non-intended use**. The user shall bear the risk for all resulting damage.



If used improperly, the possible consequences are:

- electric shock,
- severe injury to fingers and hands,
- damage to the machine,
- damage to material and malfunctioning.

Non-intended use also includes:

-  Starting the bobbin winding machine
  - without instruction from a training course or using the operating instructions,
  - with wrong direction of rotation of the main shaft.
-  Removing the cover to the housing while the bobbin winding machine is in operation or operating the machine without the cover being in place.
-  Carrying out lubricating while the bobbin winding machine is running.
-  Making alterations or modifications to the bobbin winding machine without the approval of Casati Carlo AG.
-  Using accessories and spare parts from other manufacturers without the manufacturer's approval.
-  Operating the bobbin winding machine
  - in a wet environment,
  - with inadmissible mains and compressed air variations.



## 4.2 Danger areas

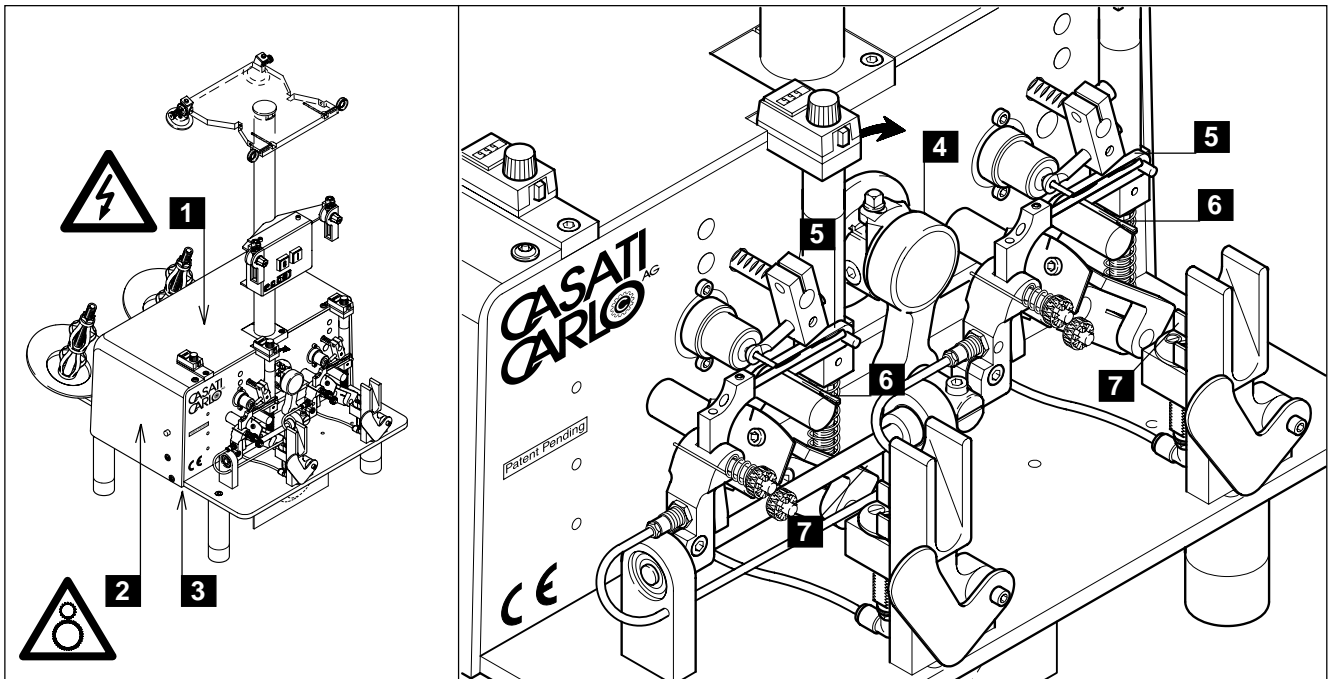

Overall view with details of the winding heads

Danger area	Danger of injury through
1 Dangerous electrical voltage within housing	- electric shock
2 Moving parts in the housing	- fingers being caught, squashed and severed - hair and clothing being entangled
3 Rotating belt drive	- fingers being caught and squashed
4 Eccentric drive	- fingers being caught and squashed between the eccentric and the thread guide lever
5 Moving thread guides	- impact, clothing becoming entangled
6 Rotating spindles	- hair becoming entangled and being torn out
7 Scissors	- being cut



### 4.3 Working safety

The locally applicable safety regulations and accident prevention rules always apply to the operation of the bobbin winding machine.

Any adjustments to the bobbin winding machine may only be made when it is standing still.

In case of unusual noises or vibrations the bobbin winding machine must be switched off and the superior responsible informed immediately.

Do not allow operating personnel to remedy faults with makeshift means. Trained and skilled persons must carry out this work, or otherwise contact Casati Carlo AG's service department.

Before maintenance and repair works make sure that the bobbin winding machine is disconnected from any power supply (all-pole) and secured against unintentional switching on.

### 4.4 Requirements of operating personnel

The operator must:

- be older than 16 years of age,
- be properly trained and instructed for the work with the bobbin winding machine,
- have read and understood the operating instructions, and section 4 "Safety" in particular.

Persons who have not completed their training may only work with the bobbin winding machine under supervision of an experienced operator.

The operator is responsible for:

- the good and safe working order of the bobbin winding machine,
- immediately reporting to his/her superior changes to the machine which affect safety,
- cleanliness and good order at the place of work.

### 4.5 Safety equipment

Long hair must either be protected (hair net) or securely bound.

The manufacturer recommends wearing:

- tight-fitting working clothing,
- noise protection, where several bobbin winding machines are simultaneously in use.



## 5. Transport

### 5.1 Packing

For shipping, the bobbin winding machine:

- is pre-assembled,
- packed in a robust carton box.

The two bobbin holders and the accessories are included.

If the bobbin winding machine is to be sent by sea freight, it is specially packed and protected against corrosion.

### 5.2 Damage in transit

Dispatch is undertaken by competent haulage contractors. Nevertheless, loss and damage can be caused during transit. For this reason, the bobbin winding machine and accessories should be checked for damage and completeness, immediately on receipt.

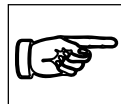

Compare the contents with the shipping documents and record damage found with photographs.

Loss and damage caused during shipping should be:

- confirmed by the haulage contractors immediately,
- reported to the insurers and manufacturer.

### 5.3 Temporary storage

Until the bobbin winding machine and accessories are set up for first use, they should be:

- stored in the original packing,
- protected against dirt and dust,
- stored under cover in a dry room.

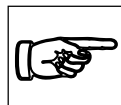

The bobbin winding machine must not be left in the open or stored in moist surroundings.



## 6. Start up

### 6.1 Setting up

Place the bobbin winding machine on a robust work table. Subsequently, screw the two cone holders tightly to the base plate and install available accessories (oiling device etc.).

A work place for the operating personnel must be provided at the front side of the bobbin winding machine with

- easy access to reset button and to cone holders,
- enough space on work table.

Between the table edge and the front side of the bobbin winding machine a distance of min. 10 cm should be provided. Here a collecting container for finished bobbins can be placed.



#### CAUTION

The electric motor is air-cooled. As a result, never place objects under the bobbin winding machine affecting the air supply.

### 6.2 Connecting compressed air

The plug connector for the compressed air supply

- can be found on the rear side of the machine, under the base plate,
- is suitable for plastic pneumatic tubes with an outer diameter of 8 mm.



#### IMPORTANT

Operating pressure and air quality of compressed air system according to Technical data, section 3.4.

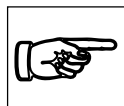

Casati Carlo AG recommends the installation of a filter unit with stopvalve and water separator.



## 6.3 Connecting electricity

**General** The standard bobbin winding machine is supplied for a mains voltage of 1 x 230V/50Hz.

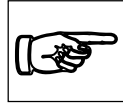

As agreed with the customer the bobbin winding machine is preset and modified to the mains voltage and frequency available at the installation site.

### Check operating voltage Procedure

 First, compare the local mains voltage with specifications on the type plate.

 In case of different mains voltage or frequency stop start up procedures and arrange further proceedings with the manufacturer.



### CAUTION

Operating the machine with inadmissible mains voltage or frequency could cause damages to machine and malfunctions.

### Preparing and connecting power line

At the working site a suitable power line should be installed. Connection to mains on rear side of machine.

The plug on the rear side of the machine  
- contains a fuse,  
- is equipped with an extra spare fuse.

If no suitable power line is available, it can be prepared using the socket supplied.

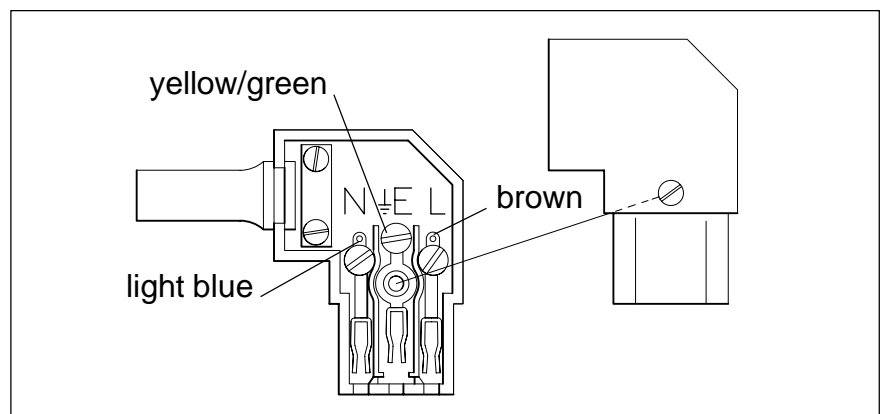

Socket



When preparing the power line, please note:

- max. cable length: 10 m
- min. cross section of wire: 1,0 mm<sup>2</sup>
- colour of wires for - phase (L): brown  
- zero conductor (N): light blue  
- protective earth (E): yellow/green

**IMPORTANT**

Power lines may only be prepared by authorized technicians according to local regulations.

Bobbing winding machine must be connected to protective conductor.





## 7. Operating

### 7.1 Operating and setting elements

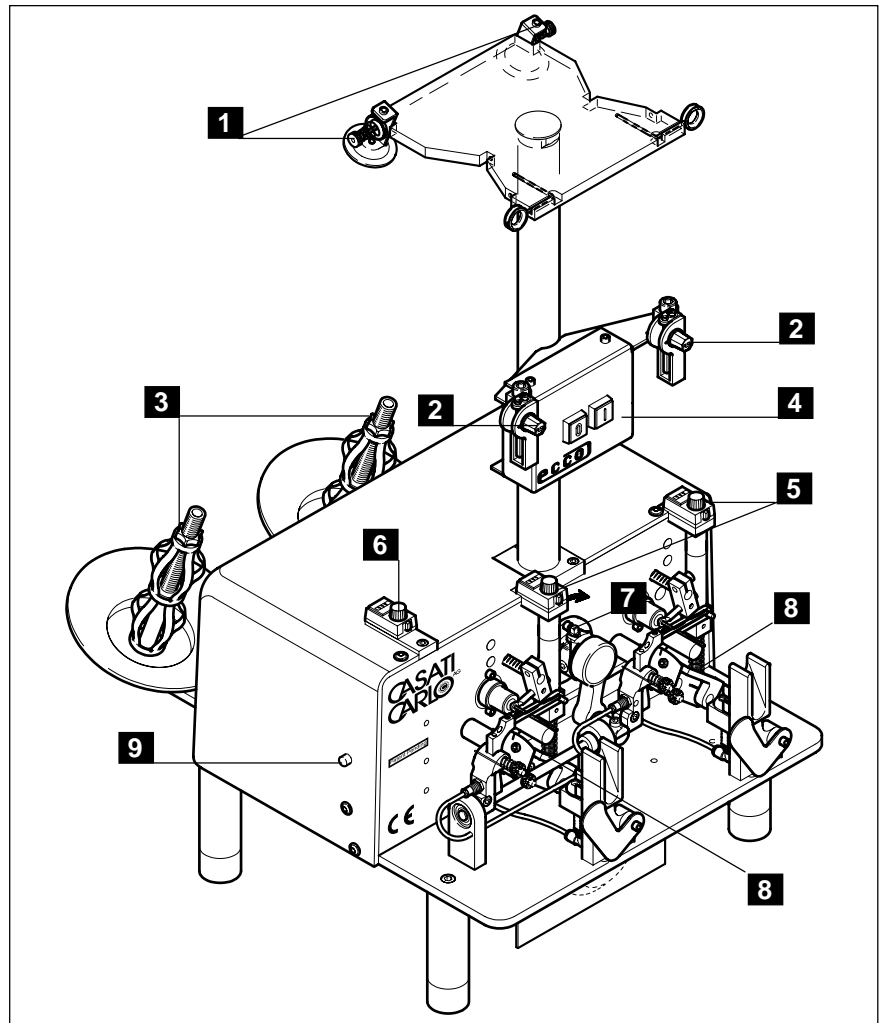

Total view

- 1 Knurled nut for regulating the inlet brakes
- 2 Knob for setting the compensators
- 3 Adjusting nut for adapting the cone holder to the different tube diameters
- 4 On/Off button for switching on/off the bobbin winding machine
- 5 Knob with setting scale for positioning the bobbin table
- 6 Knob with setting scale for setting the bobbin diameter
- 7 Adjusting screw of eccentric drive for setting the bobbin length
- 8 Adjusting nut with scale for setting the contact pressure of the bobbin table
- 9 Reset button for the manual ejection of bobbins

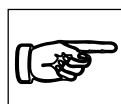

For using the setting elements refer to section 7.4 "Machine settings".



### 7.2 Start/stop/cancel winding operation

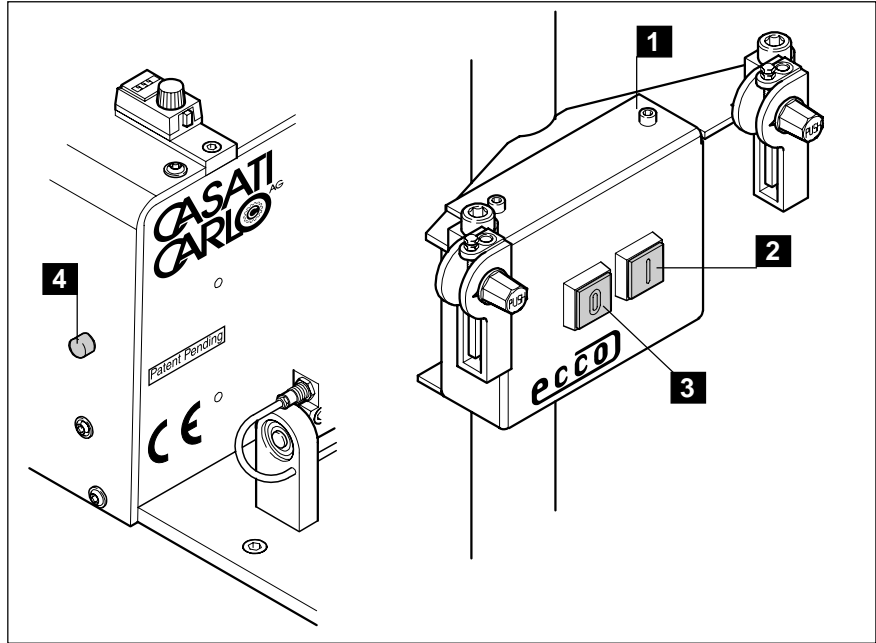

Reset button and On/Off button

The On/Off button (1)

- is mounted to the thread tree,
- has two pushbuttons for switching on/off the bobbin winding machine.

The winding operation is started with the green pushbutton (2) and stopped with the red pushbutton (3).

By pressing the Reset button (4) the bobbins can be ejected and fixed to the spindle anytime during the winding operation.



#### CAUTION

Do not switch off the bobbin winding machine during the ejection process. Possibly, with the following winding operation the bobbins are not ejected causing damage to machine.

#### Precautions

Monitor the winding operation until the first bobbins are ejected correctly.

Press the Reset button if bobbins are produced with a too large diameter. As a result, a complete ejection process is carried out and the control system of the bobbin winding machine is synchronized.



### 7.3 Setting up



#### WARNING

Danger of injuries and damage to machine if the bobbin winding machine is starting unexpectedly.

#### Precautions:

Setting up the bobbin winding machine

- may only be carried out when machine is **switched off**,
- should only be carried out by one person.

### Constitution of the thread

The maximum size of the winding for the thread is given in section 3.7 " Performance characteristics"

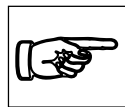

The preset direction the spindles turn determines

- the winding direction of the bobbins,
- the yarn type, particularly with strongly twisted hard yarn:

 S yarn for eccentric which turn to the right  
(spindles turn left)

 Z yarn for eccentric which turn to the left  
(spindles turn right)

### Replacement parts

Special spindle types and thread guides available as well as further accessories and setting tools can be found in index 3 to these operating instructions.

Casati Carlo AG'S advisory service is pleased to answer your queries.



**Threading**

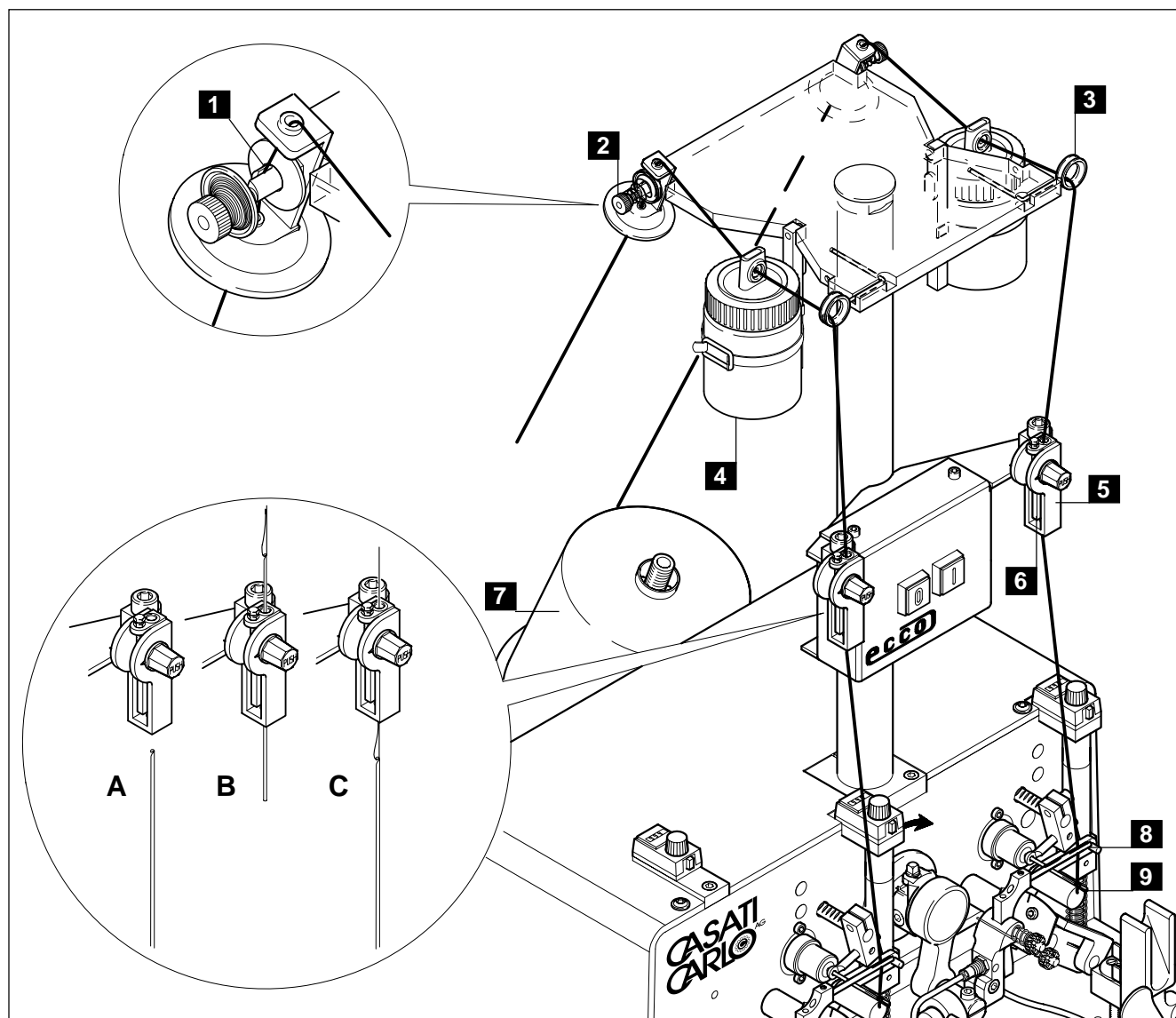

*Course of thread to the winding head*

- |                      |                |
|----------------------|----------------|
| 1 Thread guide slot  | 6 Swing lever  |
| 2 Thread brake       | 7 Cone holder  |
| 3 Thread guiding eye | 8 Thread guide |
| 4 Oiling device      | 9 Spindle      |
| 5 Compensator        |                |

The threading procedure is the same at both winding heads.

**Procedure**

- 👁 Thread the yarn through the lug of the inlet brake (2). Lift brake disk and pull yarn through the thread guide slot (1).



- 👁️ If an optional oiling device (4) is installed thread the yarn through the eye of the wick holder.
- 👁️ Next, thread the yarn into the thread guiding eye (3).
- 👁️ Step A: Press swing lever (6) manually into the compensator housing (5) and hold. Lead the threading tool (crochet hook, etc.) through the compensator with the tip from bottom to top.  
Step B: Fix yarn to the tip of the threading tool with a loop.  
Step C: Pull the threading tool downwards through the compensator. Release swing lever and check if yarn is running through all lugs of the compensator.
- 👁️ Pull yarn through the slot of the thread guide (8).
- 👁️ Wind the yarn a few times around the spindle (9) against the direction of rotation. Pull the end of the yarn through the splayed end of the spindle to secure it.

## 7.4 Machine setting

The machine setting

- determines the dimensions and properties of the bobbins,
- adapts the bobbin winding machine to the yarn used.

Every bobbin winding machine is delivered by the manufacturer with either a standard setting or one requested by the customer.

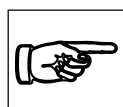

### Important

For the first setting of the machine special knowledge and experience is required. For this reason the manufacturer recommends:

- 👁️ That only trained persons should be responsible for the first setting of the machine at the place of operation.
- 👁️ That each resetting should be put down on index 4 of these Operating Instructions.

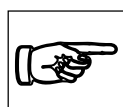

Under index 4 special sheets can be found for putting down all important machine settings. With the help of these documents settings on the bobbin winding machine can be carried out quickly and trouble-free even by inexperienced operating personnel.



**Machine setting  
(continued)**

For customers Casati Carlo AG offers the following:

- 👁️ Special courses about machine setting.
- 👁️ Setting the bobbin winding machine(s) at the customer's premises.
- 👁️ A regulation kit with measuring devices and special tools for machine setting (see index 3).

**Setting instructions**

The settings on the bobbin winding machine in part affect each other. For this reason, the following procedure is recommended with resetting:

- 👁️ Carry out each setting at a winding head only in single steps.
- 👁️ Carry out a test run with min. two bobbins.
- 👁️ Use the setting tested for the other winding head. Settings for the two winding heads must always be identical.

**Setting eccentric deflection**

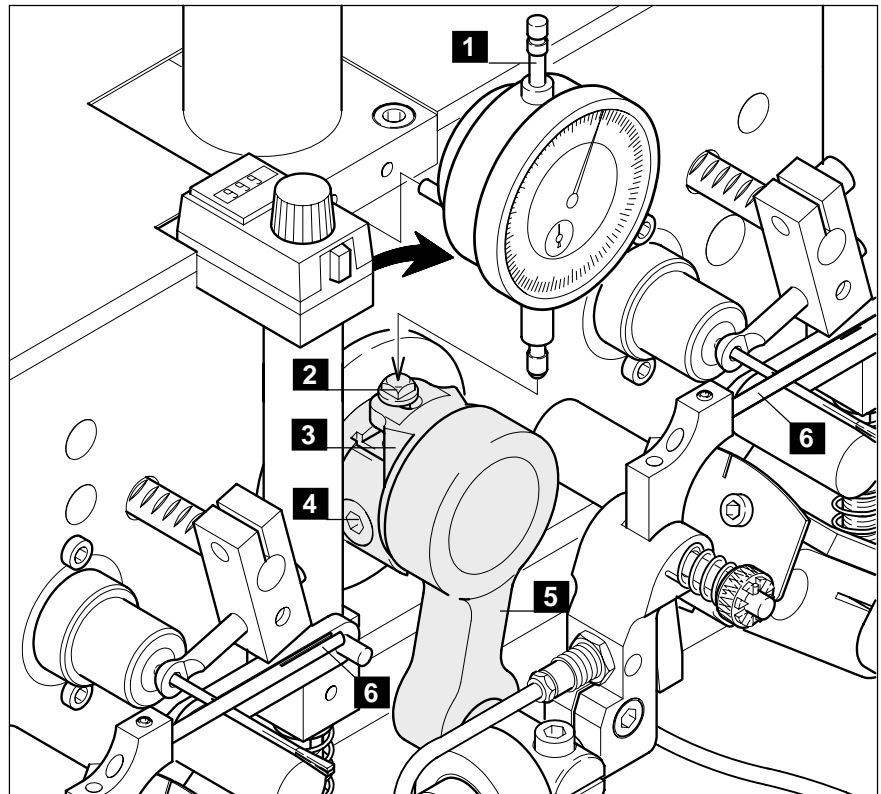

Front view

- |                   |                  |
|-------------------|------------------|
| 1 Dial gauge      | 4 Clamping screw |
| 2 Adjusting screw | 5 Connecting rod |
| 3 Eccentric       | 6 Thread guide   |

This setting

- determines the bobbin length of **both** winding heads,
- changes the travel of the thread guide,
- is only possible during standstill.

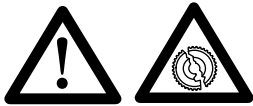
**WARNING**

Danger of injuries and damage to machine if the bobbin winding machine is starting unexpectedly.



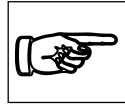

**Precaution:**

Only one person may work at the bobbin winding machine.



For this setting a modified dial gauge is helpful (see index 3). Instead of the dial gauge the stroke of the eccentric can be measured using a caliper rule.

**Procedure:**

-  Undo the clamping screw (4) by a quarter turn using a 5 mm hexagonal key.
-  Adjust connecting rod (5) by hand until adjusting screw (2) is exactly vertical.
-  Insert pins of dial gauge (1) into holes of thread tree.
-  Press feeler pin onto the adjusting screw with finger.
-  Now turn the adjusting screw with a open-end wrench:



Clockwise = the bobbin length becomes shorter.



Anti-clockwise = the bobbin length becomes longer.

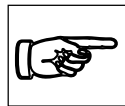

With the basic setting the travel of the thread guide should be 1 to 1.5 mm more than the bobbin length. The stroke can be determined as follows: Measure the max. and min. distance between thread guide and housing using a caliper rule and calculate the difference of both distance values.

-  When setting is finished
  - take down the measured value indicated,
  - remove dial gauge,
  - re-tighten the clamping screw.

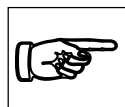

When setting the eccentric according the sheet "Machine settings" the backlash of the adjusting screw must be always considered.



## Setting the thread guide

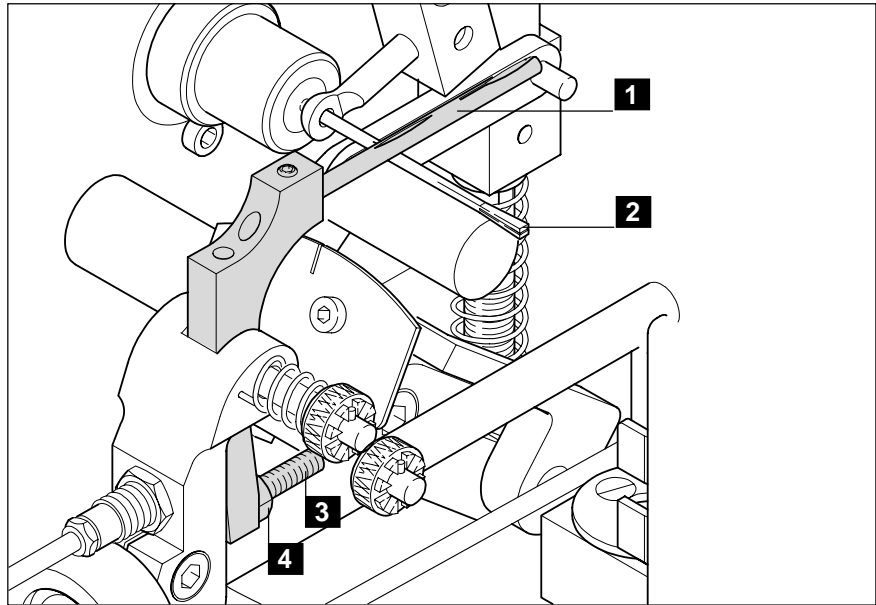

*Detailed view of winding head*

- |                |             |
|----------------|-------------|
| 1 Thread guide | 3 Stud bolt |
| 2 Spindle      | 4 Lock nut  |

This setting



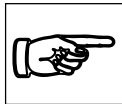



- determines the distance between the thread guide and the spindle,
- determines the shape of the bobbins,
- may only be carried out during standstill.

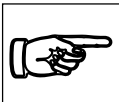

### IMPORTANT

Adjust thread guide only after the eccentric stroke is determined (see previous page).

### Procedure

-  Undo lock nut (4).
-  Turn stud bolt (3) to lift/lower the thread guide.
-  For the **basic setting** set thread guide to centre position.
-   Measure distance between thread guide and base plate using the depth gauge of a caliper rule: vertical and to the left of the bobbin table.
-  Set thread guide to a distance of 131.5 mm to the base plate with the stud bolt.
-  Tighten lock nut.





-  After fine adjustment take down the distance to the base plate and use it for setting the second thread guide.

### Setting the bobbin diameter

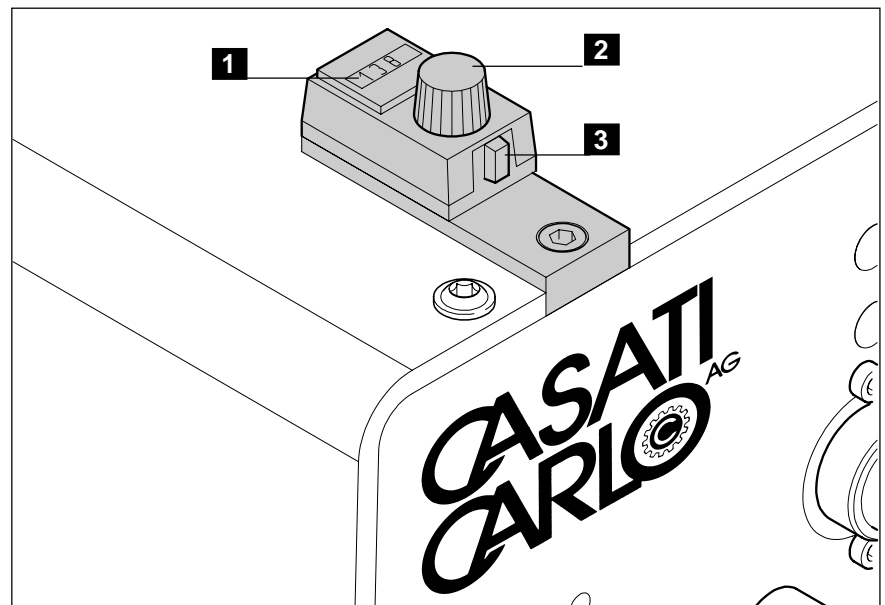

Front view

- 1 Counter  
2 Setting knob  
3 Locking lever

This setting

- determines the bobbin diameter of both winding heads,
- determines the max. distance between bobbin tables and spindles where the diameter opening is triggered,
- can also be carried out when bobbin winding machine is running.

### Procedure

-  Press locking lever (3) to the left.

-  Now turn the setting knob (2):  
Clockwise = bobbin diameter becomes larger.  
Anti-clockwise = bobbin diameter becomes smaller.

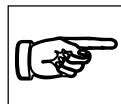

After each setting check the bobbin diameters of minimum two production cycles.

-  After checked setting
- read off the counter (1) and take down the indicated value,
  - press locking lever to the right.



## Setting the bobbin tables

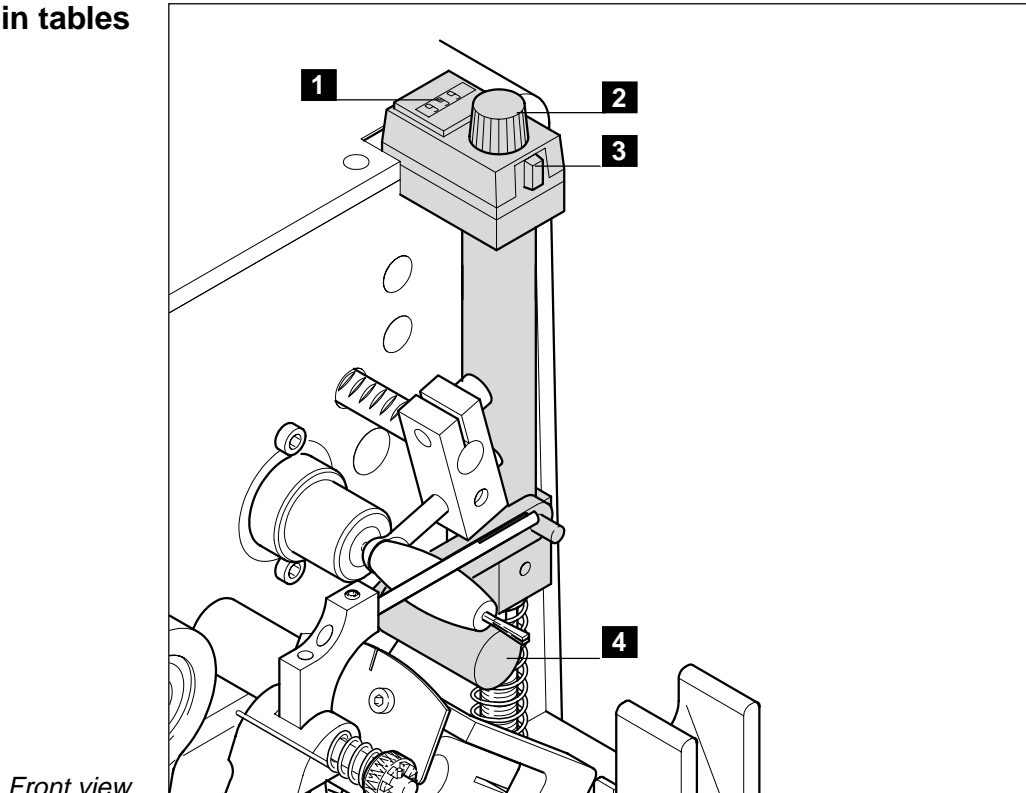

1 Counter  
2 Setting knob

3 Locking lever  
4 Bobbin table

### This setting

- determines the distance between the bobbin table (4) and the spindle,
- determines the form of the bobbin,
- can also be carried out when bobbin winding machine is running.

### Procedure

 Press locking lever (3) to the left.

 Now turn the setting knob (2):



Clockwise = the bobbin is more chased.



Anti-clockwise = the bobbin is less chased.

 When setting is finished

- read off the counter (1) and take down the indicated value,
- press locking lever to the right.



### Setting the contact pressure of the bobbin tables

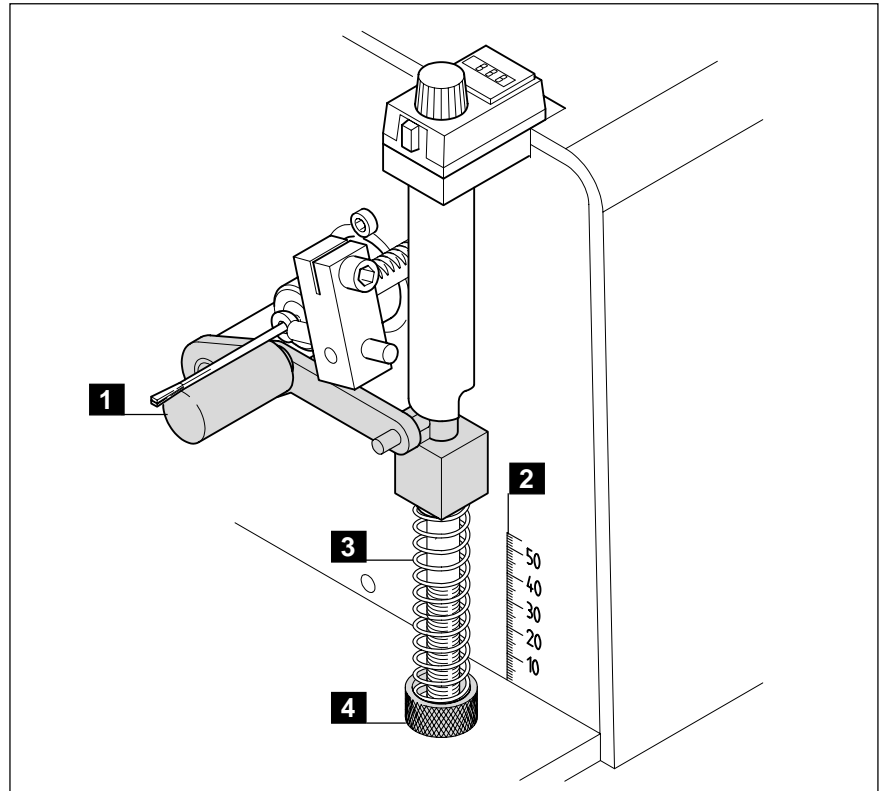

Front view

1 Bobbin table  
2 Height scale

3 Spring  
4 Adjusting nut

The setting of the spring (3)

- determines the contact pressure of the bobbin table (1) to the bobbin,
- determines the bobbin hardness.
- may only be carried out during standstill.

### Procedure

 Turn the adjusting nut (4):



Upwards - the bobbin becomes harder.



Downwards – the bobbin becomes softer.

 When setting is finished read off the position of the adjusting nut's lower edge from the scale (2) and take it down.



## Setting the inlet brake

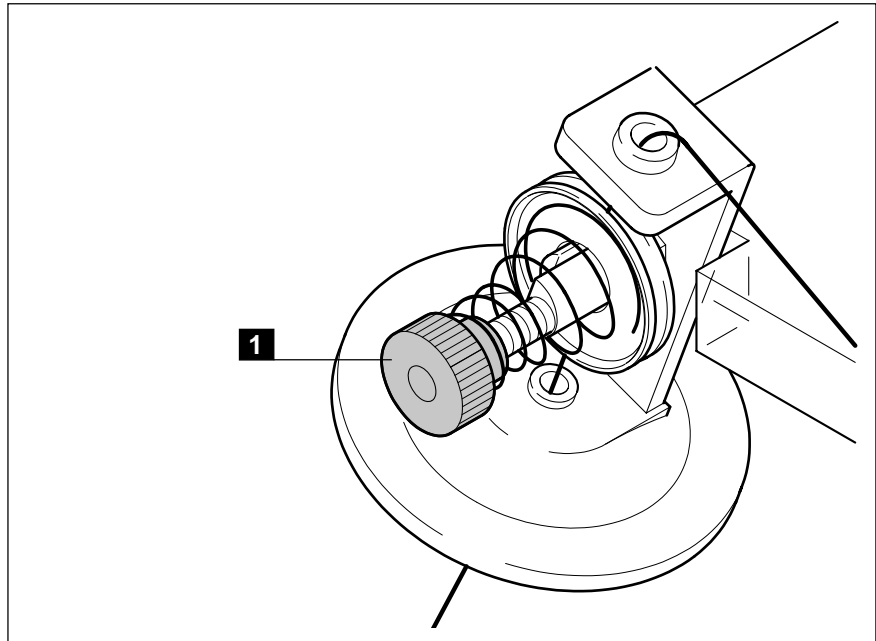

*Detailed view of inlet brake*

Setting the inlet brake affects

- the yarn tension,
- the bobbin hardness,
- the thread length winded on bobbin.

The inlet brakes are adjusted with bobbin winding machine running.

### Procedure:

 Turn the knurled nut (1):

Clockwise = the braking effect and the yarn tension is increased.

Anti-clockwise = the braking effect and the yarn tension is decreased.

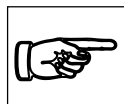

### Important

For a correct function of the thread measuring device a minimum yarn tension of 25 cN is required (measured **after** the inlet brake).

The inlet brakes for both winding heads

- must be set so that they are identical,
- must be adjusted if there are tolerance deviations between the thread lengths of both winding heads.



## Setting the compensator

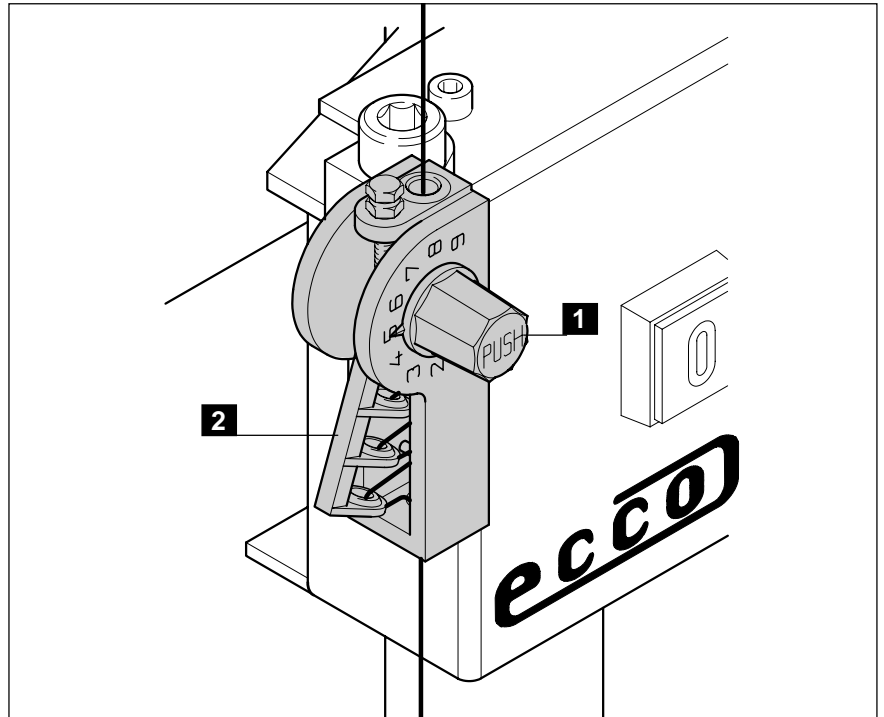

*Detailed view of compensator*

The compensator

- dampens the jerky course of the thread from the thread guide with its swing lever (2),
- is set when bobbin winding machine is running.

With knob (1) the deflection force of the swing lever can be adjusted gradually from 1 to 9.

### Procedure:

- Press knob into direction of the compensator housing and set to desired number **simultaneously**:

Turn clockwise = deflection force is increased.

Turn anti-clockwise = deflection force is decreased.

- Read off set value and take it down.

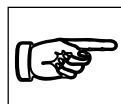

### Important

- During winding operation the swing lever should be freely movable without bouncing against the housing or swinging out into the end position completely.
- With each changing of the yarn tension with the inlet brake also the compensator setting must be checked.
- If the compensator is wrongly adjusted the thread length of the two winding heads can be different.



## 7.5 Bobbin sizes

The following table gives the bobbin dimensions for normal shuttle sizes (accuracy not guaranteed).

Shuttle no.	Diameter x Length Dimensions in mm	Notes
4	10,8 x 33,0	
5	10,2 x 31,0	
6	11,7 x 34,5	
7	12,0 x 35,0	
S2	12,2 (11,9) x 35,0	
8	13,0 x 37,0 (34,5)	
9	12,5 x 36,0	
10 (Top)	14,5 x 42,0	
11	15,5 x 45,0	

## 7.6 Operating instructions

**Checks** Check **before** switching on:

- Is the
  - bobbin winding machine set to desired bobbin?
  - bobbin winding machine completely set up?
  - yarn correctly thread?
- Are all setting parameters correct?
- Are tools, measuring instruments, etc. still on the bobbin winding machine?

Check **during** winding operation:



- If the bobbin winding machine makes unusual noises switch off immediately and request a trained person to find the fault.



- Unauthorised persons (children) must not be present in the area of the bobbin winding machine – there is a danger of injury.



- Check bobbin winding machine(s) periodically for
  - thread breakages,
  - empty cones,
  - full collecting container.

**CAUTION**

If the bobbin winding machine is stopped during ejection of bobbins due to a power or compressed air failure it is possible that the secondary shaft stops undefined. Possibly, with the following winding operation the bobbins are not ejected causing damage to machine.

**Precaution**

Monitor the winding operation until the first bobbins are ejected correctly.

Press the reset button if bobbins are produced with a too large diameter. As a result, a complete ejection process is carried out and the control system of the bobbin winding machine is synchronized.

**Hints for making bobbins**

1. Make sure that the machine settings for both winding heads are the same.
2. The distance between the bobbin table and the spindle influences shape and unwinding length of a bobbin:



- Small distance – cylindrical shape of bobbin; higher unwinding length.



- Great distance – barrel shape of bobbin; lower unwinding length.

3. Using the inlet brake set a yarn tension of approx. 30% to 40% of the min. tensile strength. With this value relative hard bobbins with good unwinding properties can be produced.

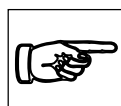

The dynamic thread tension during winding operation can be several times the basic setting!

4. For optimizing the bobbin hardness increase the thread tension at both winding heads step by step and simultaneously. In case of repeated thread breakages reduce slightly.

**Hints for making bobbins  
(continued)**

5. The weight of the bobbin depends on the unwinding length. Using a precision balance check both bobbins of one ejection. As an example, the permissible weight difference between both bobbins must be specified in a production standard.

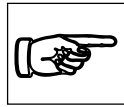

The precision balance used should have a resolution of 0.001 gram.

6. The unwinding length of the bobbin can be influenced by changing the yarn tension: With the lighter bobbin reduce the yarn tension step by step at the winding head. After each changing check weight of several bobbins until the weight difference is within the tolerance value.

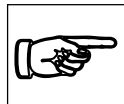

Constant measuring results are only possible after a winding operation of several minutes under production conditions.

7. If bobbin weight and unwinding length is not sufficiently reproducible: Increase the anti-friction property of the yarn by oiling. The oiling device is described under section 2.6 "Options".
8. In case of irregular unwinding of the bobbins and uncontrolled contracting together of the yarn during start of winding: Change spring force and spindle distance of both bobbin tables.





7.7 Diagnosis



Faults arising may only be remedied  
- by qualified personnel,  
- when the bobbin winding machine is standing still.

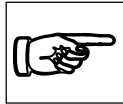

All settings should be carried out by the same person.

Problem	Possible cause(s)	Remedy
1 The bobbin winding machine cannot be started.	Mains connection interrupted.	<ul style="list-style-type: none"> <li>• Check mains connection.</li> </ul>
	Instrument fuse triggered.	Acc. to fig. 1 and description in chapter 9 "Repair": <ul style="list-style-type: none"> <li>• Remove cause of overload.</li> <li>• Pull mains plug and replace instrument fuse.</li> </ul>
	No compressed air available.  Operating pressure too low.	<ul style="list-style-type: none"> <li>• Check compressed air connection.</li> <li>• Set operating pressure to min. 5.5 bar.</li> </ul>
	Temperature switch of electric motor overheated: <ul style="list-style-type: none"> <li>• Drive braked or blocked.</li> <li>• Faulty electric motor.</li> </ul>	<ul style="list-style-type: none"> <li>• Remove cause of overload.</li> <li>• Let cool down electric motor.</li> <li>• Check electric motor and replace, if necessary.</li> </ul>

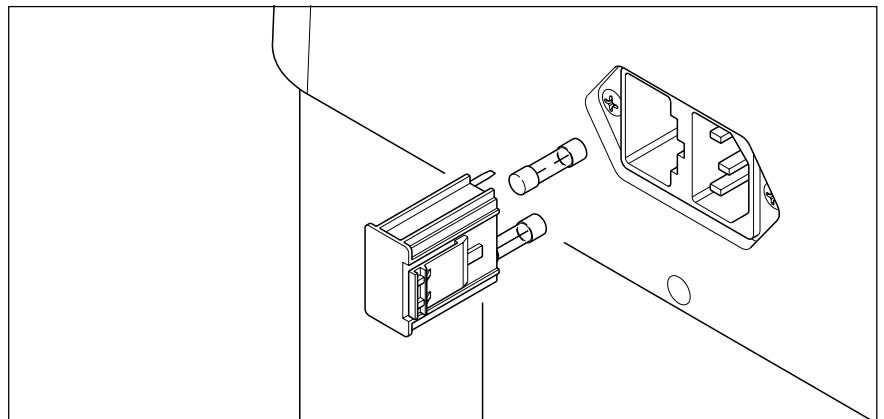

Fig. 1) Replacing instrument fuse



Problem	Possible cause(s)	Remedy
<p>2 Bobbin too long.</p>	<p>The eccentric's stroke is too long.</p>	<ul style="list-style-type: none"> <li>• Measure bobbin length with caliper rule.</li> </ul> <p>Set bobbin length following fig. 2:</p> <ul style="list-style-type: none"> <li>• Undo the clamping screw of eccentric by a quarter turn using a 5 mm hexagonal key.</li> <li>• Move connecting rod by hand until adjusting screw of eccentric is exactly vertical.</li> <li>• Insert pins of dial gauge into holes of thread tree.</li> <li>• Press feeler pin onto the adjusting screw with finger and take down measured value.</li> <li>• Turn adjusting screw clockwise with an open-end wrench (until dial gauge shows set value acc. to machine setting sheet):</li> </ul> <p><b>Important:</b> The backlash of the adjusting screw must be always considered.</p> <ul style="list-style-type: none"> <li>• Remove dial gauge, take down the measured value and re-tighten the clamping screw.</li> <li>• Start winding process, measure length of bobbins produced and repeat setting, if required.</li> </ul>
<p>3 Bobbin too short.</p>	<p>The eccentric's stroke is too short.</p>	<p>Make settings as described above; but turn adjustment screw anti-clockwise.</p>

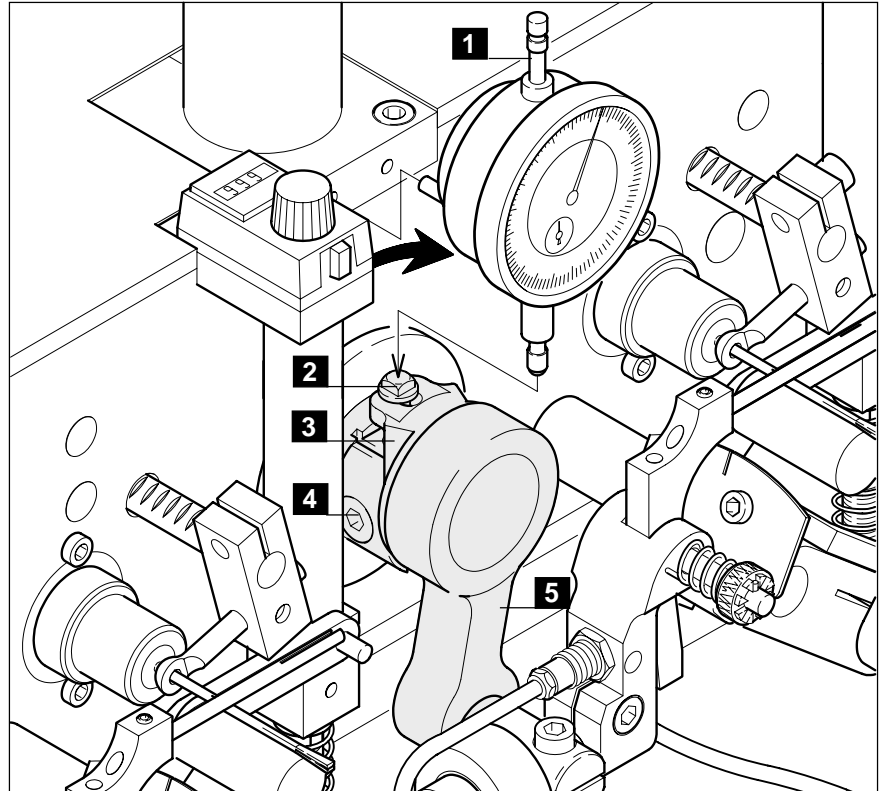

Fig. 2) Setting stroke of eccentric

- 1 Dial gauge
- 2 Adjusting screw
- 3 Eccentric

- 4 Clamping screw
- 5 Connecting rod



Problem	Possible cause(s)	Remedy
4 Bobbin too pointed.	Clearance between bobbin table and spindle too great.	Reduce distance (fig. 3): <ul style="list-style-type: none"> <li>• Press locking lever to left.</li> <li>• Turn setting knob anti-clockwise.</li> <li>• Press locking lever to right.</li> <li>• Take down counter indication.</li> </ul>
	Thread guide too low.	Lift thread guide (fig. 4): <ul style="list-style-type: none"> <li>• Undo lock nut.</li> <li>• Set thread guide with bolt to desired height.</li> <li>• Re-tighten lock nut.</li> <li>• Measure distance between thread guide and base plate (see section 7.4) and take down.</li> </ul>
	Yarn tension too low.	<ul style="list-style-type: none"> <li>• Determine yarn tension with measuring instrument.</li> <li>• Increase yarn tension with knurled nut of inlet brake (fig. 5).</li> <li>• Measure new yarn tension and take down.</li> </ul>
	Bobbin tables' pressure is too little.	<ul style="list-style-type: none"> <li>• Determine pressure of bobbin table with measuring instrument.</li> <li>• Turn adjusting nut anti-clockwise to increase pressure of bobbin table (fig. 6).</li> <li>• Take down new pressure (measured value or scale indication).</li> </ul>

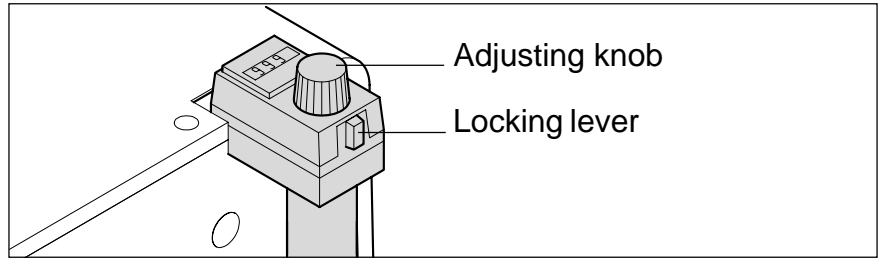

Fig. 3) Setting the bobbin table

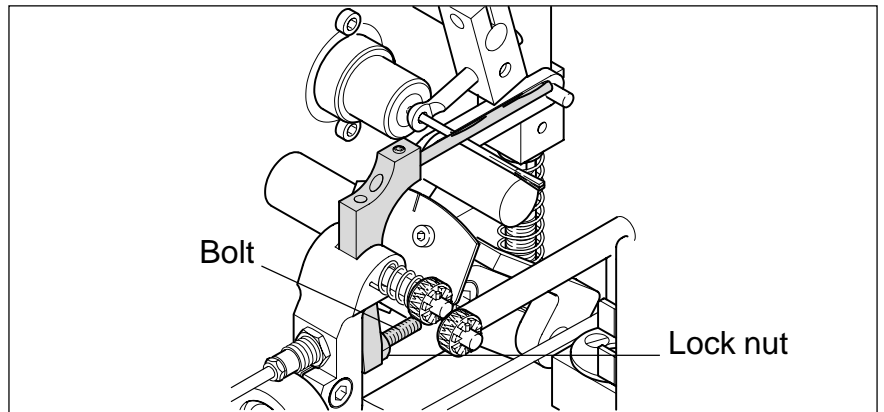

Fig. 4) Lifting/lowering thread guide

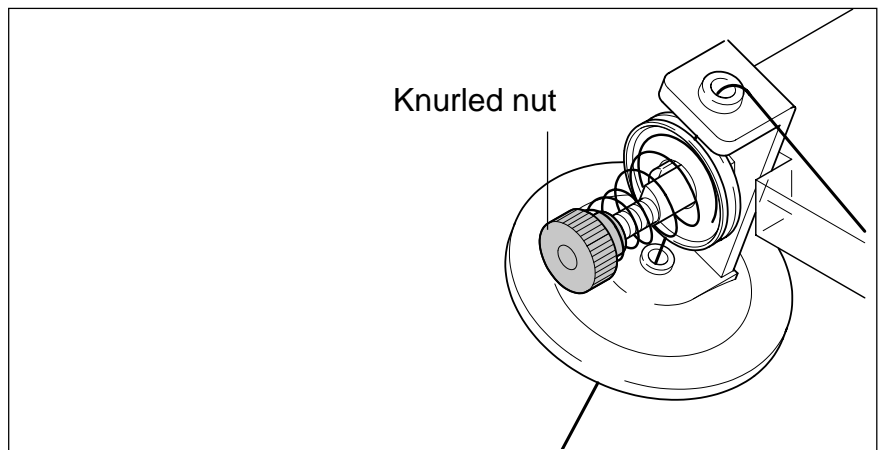

Fig. 5) Setting the inlet brake

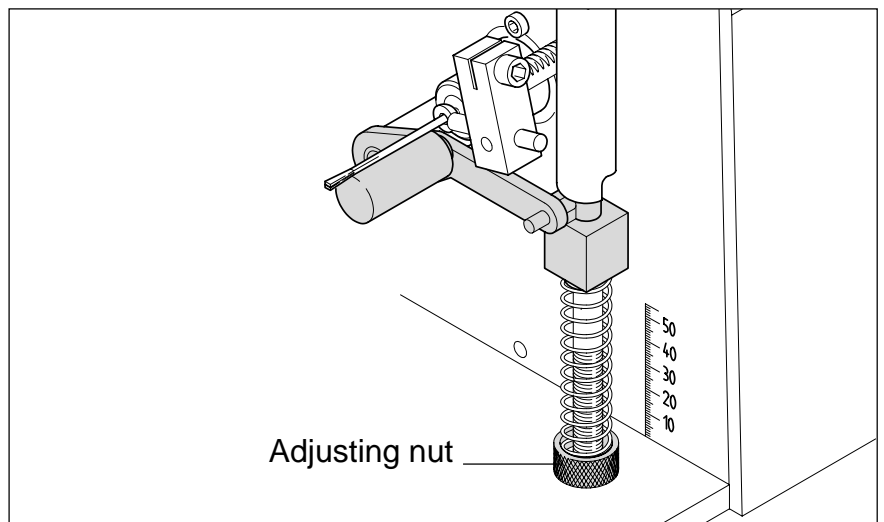

Fig. 6) Setting the bobbin tables' pressure



Problem	Possible cause(s)	Remedy
5 Bobbin ends too flat.	Clearance between bobbin table and spindle too small.	Increase distance (fig. 3): <ul style="list-style-type: none"> <li>• Press locking lever to left.</li> <li>• Turn setting knob clockwise.</li> <li>• Press locking lever to right.</li> <li>• Take down counter indication.</li> </ul>
	Thread guide too high.	Lower thread guide (fig. 4): <ul style="list-style-type: none"> <li>• Undo lock nut.</li> <li>• Set thread guide with bolt to desired height.</li> <li>• Re-tighten lock nut.</li> <li>• Measure distance between thread guide and base plate (see section 7.4) and take down.</li> </ul>
	Yarn tension too high.	<ul style="list-style-type: none"> <li>• Determine yarn tension with measuring instrument.</li> <li>• Decrease yarn tension with knurled nut of inlet brake (fig. 5).</li> <li>• Measure new yarn tension and take down.</li> </ul>
	Bobbin tables' pressure too high.	<ul style="list-style-type: none"> <li>• Determine pressure of table with measuring instrument.</li> <li>• Turn adjusting nut clockwise to decrease pressure of table (fig. 6).</li> <li>• Take down new pressure (measured value or scale indication).</li> </ul>

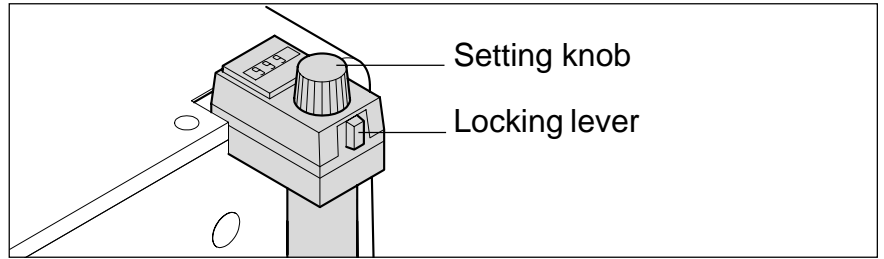

Fig. 3) Setting the bobbin table

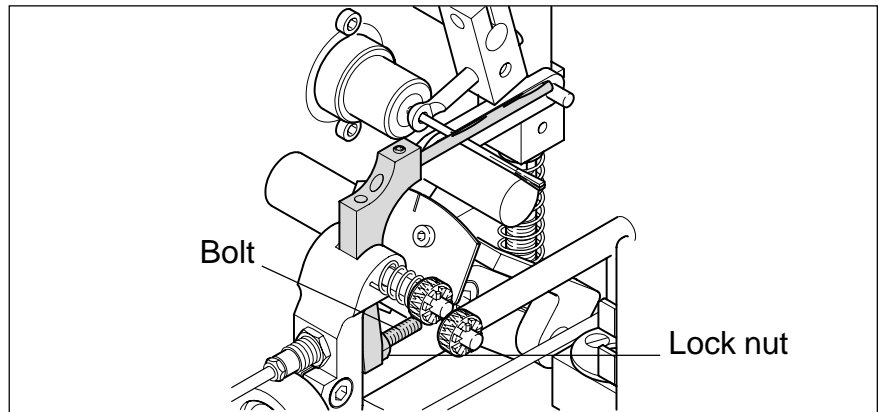

Fig. 4) Lifting/lowering thread guide

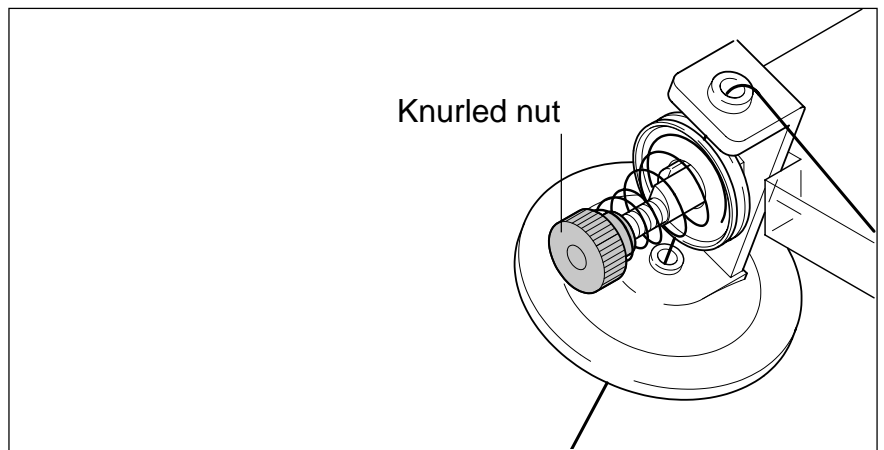

Fig. 5) Setting the inlet brake

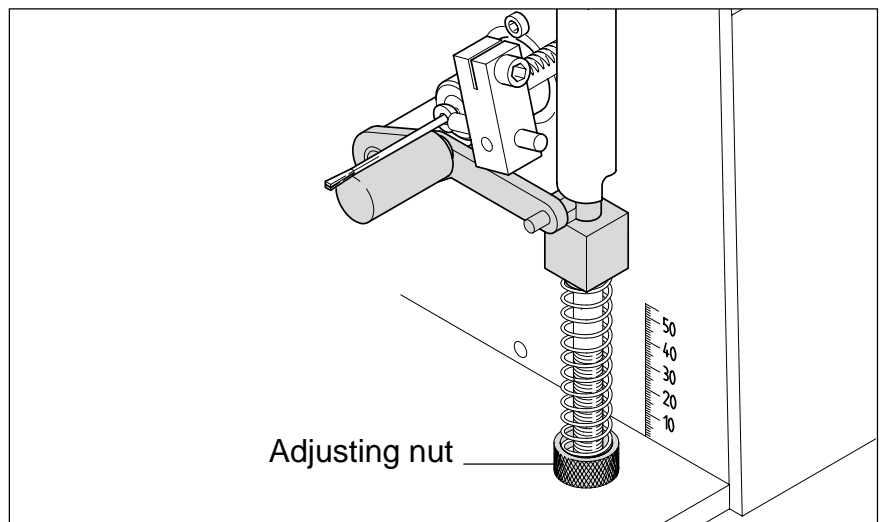

Fig. 6) Setting the bobbin tables' pressure



Problem	Possible cause(s)	Remedy
6 Bobbin table over-heated (only valid for sliding tables).	Bobbin tables' pressure too high.	<ul style="list-style-type: none"> <li>• Determine pressure of table with measuring instrument.</li> <li>• Turn adjusting nut clockwise to decrease pressure of table (fig. 6).</li> <li>• Take down new pressure (measured value or scale indication).</li> </ul> <p>Important: The shape of the bobbin changes after this adjustment is made (note points 4 and 5).</p> <ul style="list-style-type: none"> <li>• Lubricate yarn (optional oiling device (fig. 7).</li> </ul>
	Friction too high.	<ul style="list-style-type: none"> <li>• Use rolling table.</li> </ul>
7 Bobbin diameter too big.	Too much thread on bobbin.	<ul style="list-style-type: none"> <li>• Measure bobbin diameter with caliper rule.</li> <li>• Press locking lever to left (fig. 8).</li> <li>• Turn setting knob anti-clockwise.</li> <li>• Press locking lever to right.</li> <li>• Take down counter indication.</li> </ul>
	Wrong thread.	<ul style="list-style-type: none"> <li>• Use correct thread.</li> </ul>





Fig. 6) Setting the bobbin tables' pressure

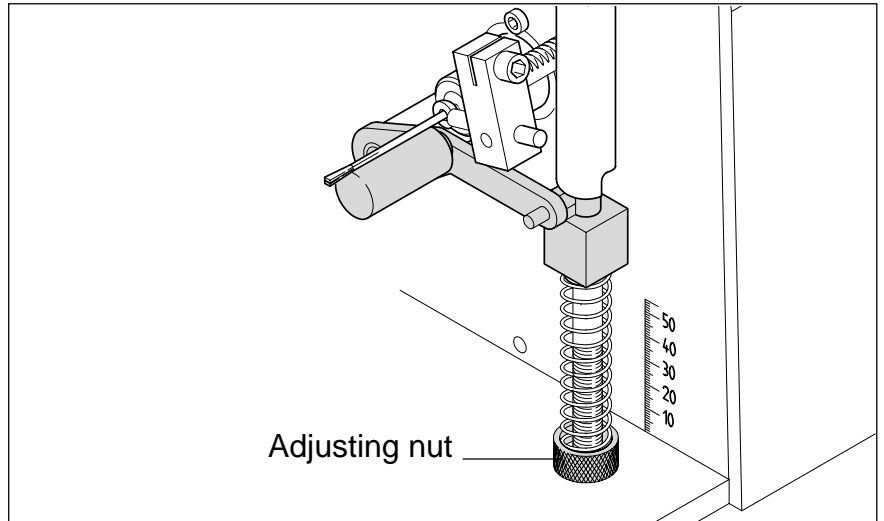

Fig. 7) Oiling device (option)

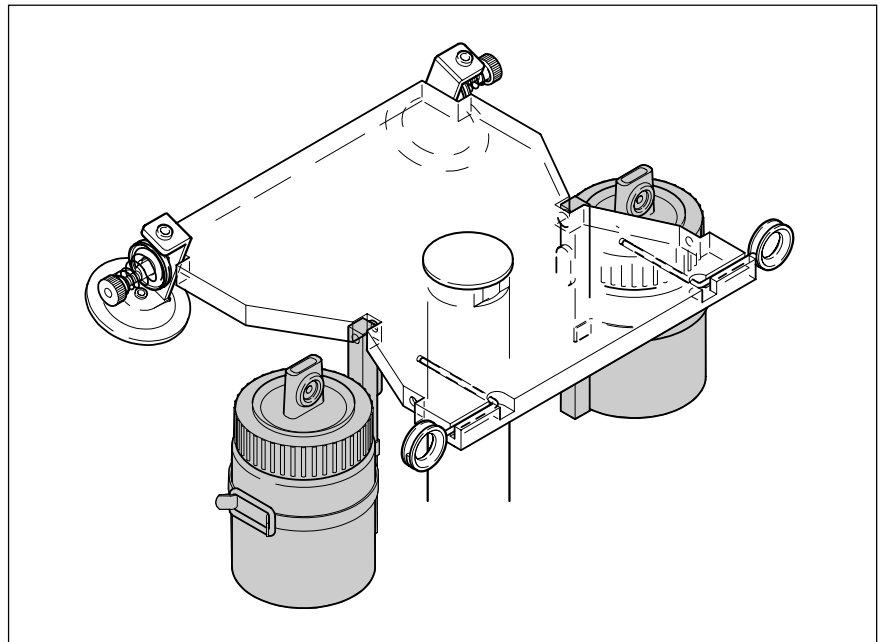
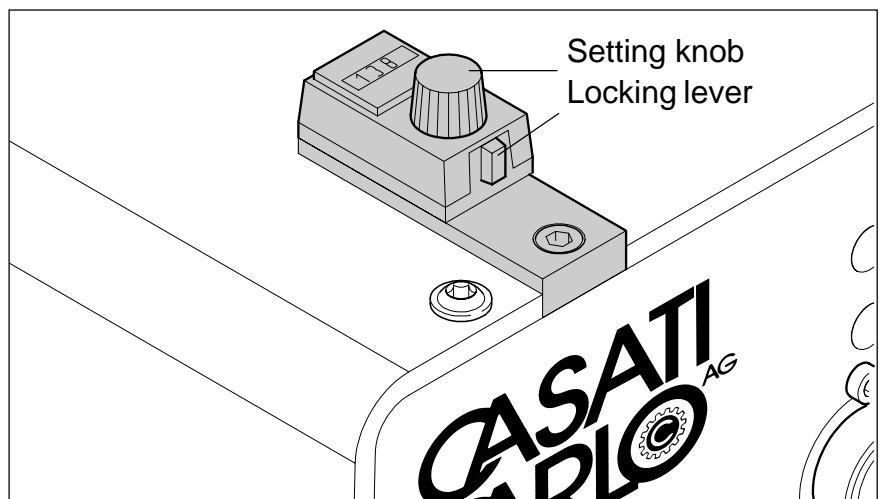

Fig. 8) Setting bobbin diameter





Problem	Possible cause(s)	Remedy
8 Bobbin diameter too small.	Not enough thread on bobbin.	<ul style="list-style-type: none"> <li>• Measure bobbin diameter with caliper rule.</li> <li>• Press locking lever to left (fig. 8).</li> <li>• Turn setting knob clockwise.</li> <li>• Press locking lever to right.</li> <li>• Take down counter indication.</li> </ul>
	Wrong thread.	<ul style="list-style-type: none"> <li>• Use correct thread.</li> </ul>
9 Bobbins of both winding heads are different in - diameter, - weight.	Cones are different in - thread thickness, - thread quality.	<ul style="list-style-type: none"> <li>• Check cones and replace, if required.</li> </ul>
	Different yarn tensions.	<ul style="list-style-type: none"> <li>• At both winding heads after the inlet brake: Check yarn tension with measuring instrument and adjust to each other subsequently (fig. 5).</li> </ul>
	At one of both winding heads - the thread is not correctly running through the compensator, - the compensator is wrongly adjusted.	<ul style="list-style-type: none"> <li>• Using the threading tool, thread the yarn through the compensator (refer to fig. 9 and section 7.3 "Setting up").</li> <li>• Check both compensators for easy movement and same setting.</li> </ul>

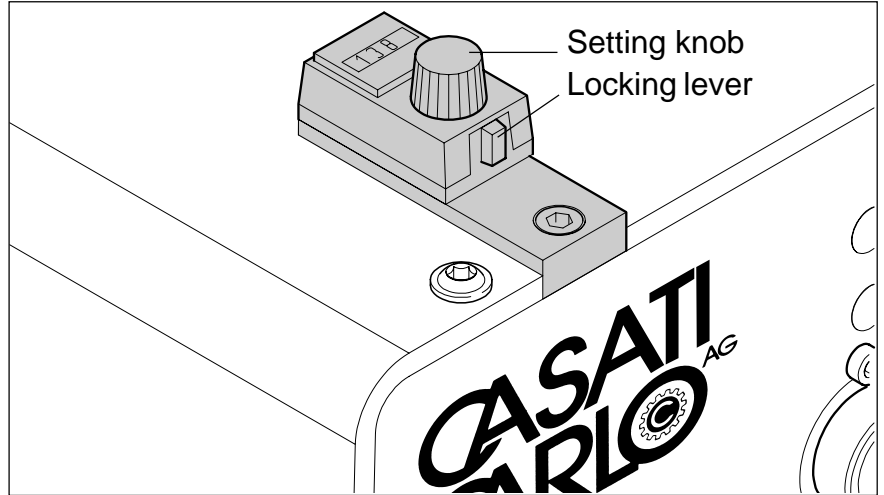

Fig. 8) Setting bobbin diameter

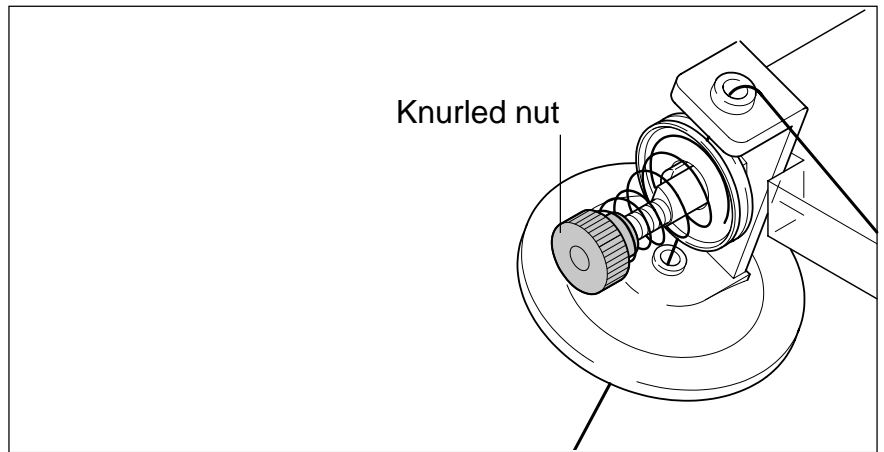

Fig. 5) Setting the inlet brake

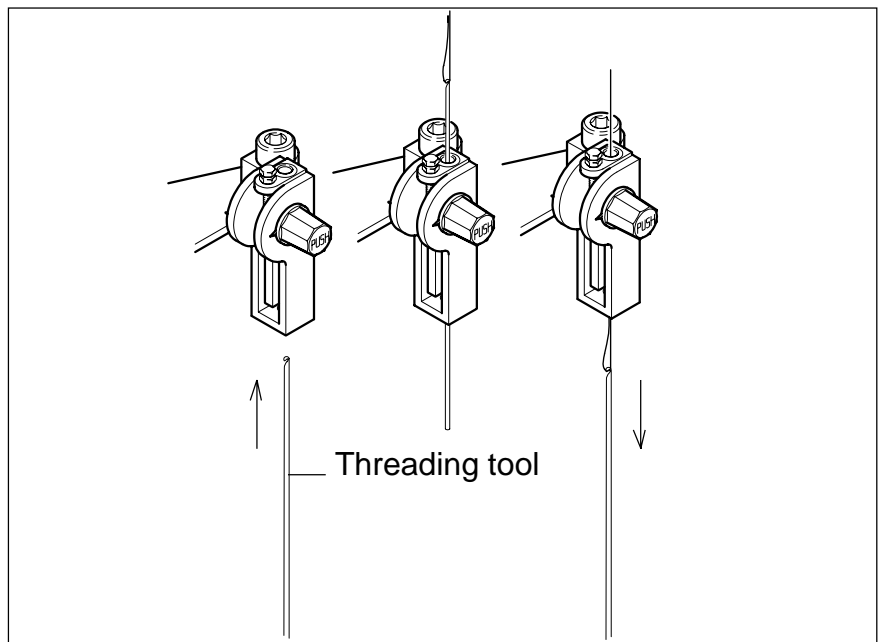

Fig. 9) Threading yarn into compensator



Problem	Possible cause(s)	Remedy
10 Bobbin is squashed on being pushed out from the spindle.	Thread tension too low.	<ul style="list-style-type: none"> <li>• Determine yarn tension with measuring instrument.</li> <li>• Turn knurled nut of inlet brake clockwise (fig. 5).</li> <li>• Measure yarn tension again and take down measured value.</li> </ul>
	Bobbin tables' pressure too low.	<ul style="list-style-type: none"> <li>• Determine pressure of table with measuring instrument.</li> <li>• Turn adjusting nut clockwise to increase pressure of table (fig. 6).</li> <li>• Take down new pressure (measured value or scale indication).</li> </ul> <p>Important: The shape of the bobbin changes after this adjustment is made (note points 4 and 5).</p>
	Adhesion to the spindle too strong.	<ul style="list-style-type: none"> <li>• Polish the spindle or replace by more suitable type.</li> </ul>
11 Jerky run-out of the bobbin from the shuttle.	Shuttle wrongly set or faulty.	<ul style="list-style-type: none"> <li>• Re-adjust shuttle or replace.</li> </ul>
	Start of bobbin contracts uncontrollably.	<p>Change clearance between bobbin table and spindle (fig. 3):</p> <ul style="list-style-type: none"> <li>• Loosen locking lever.</li> <li>• Turn setting knob clockwise or anti-clockwise.</li> <li>• Lock locking lever and take down counter indication.</li> <li>• Start winding operation and check bobbins already produced.</li> </ul>

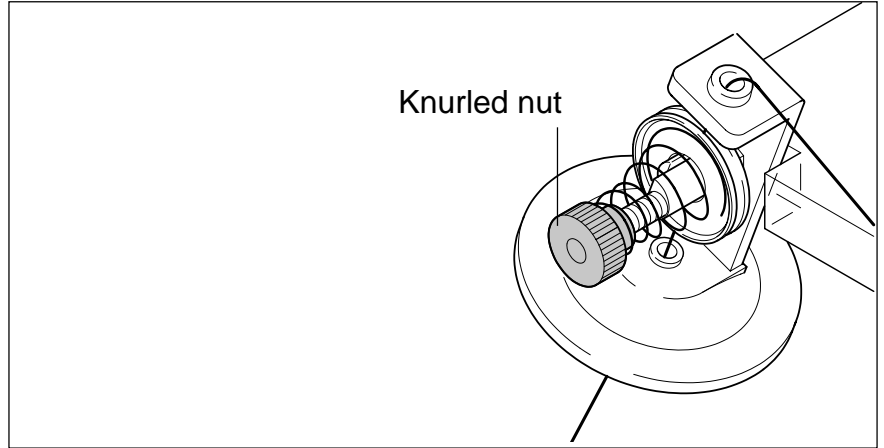

Fig. 5) Setting the inlet brake

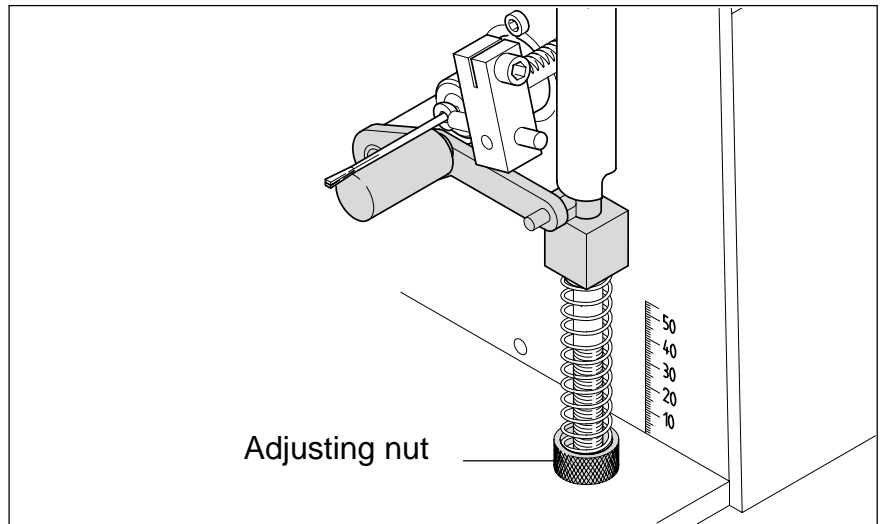

Fig. 6) Setting the bobbin tables' pressure

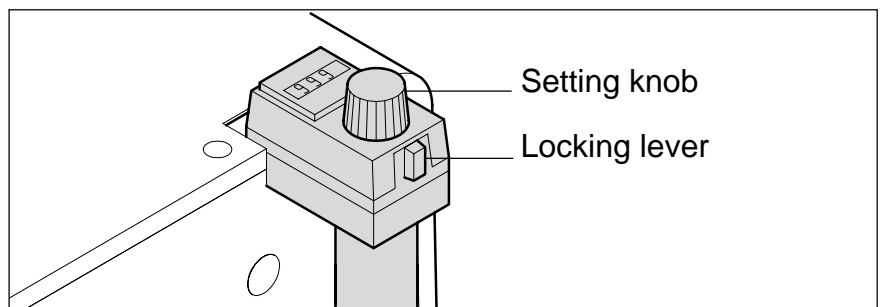

Fig. 3) Setting the bobbin table



Problem	Possible cause(s)	Remedy
11 Jerky run-out of the bobbin from the shuttle (contd.).	Thread tension too high or too low.	<ul style="list-style-type: none"> <li>• Check thread tension and correct.</li> </ul>
	Material properties of polyester threads are altered during winding.	<ul style="list-style-type: none"> <li>• Check bobbins already produced and thermal retreat, if required.</li> </ul>
12 Bobbin is not properly undertucked.	Tucker plate pressure too low.	<ul style="list-style-type: none"> <li>• Press in spring setting ring and turn clockwise (fig. 10).</li> </ul>
	Wrong position of undertucker.	<p>Adjust undertucker (fig. 11):</p> <ul style="list-style-type: none"> <li>• Place suitable adjusting gauge onto round spindle.</li> </ul> <p>Find adjusting gauges with outer diameter of normal bobbins in the regulation kit.</p> <ul style="list-style-type: none"> <li>• Position tucker plate: Press reset button. Press red key „0“ as soon as the tucker plate is in its highest position during ejection.</li> <li>• Undo lock nut.</li> <li>• Turn thread plug with Allen key until the undertucker touches the adjusting gauge at the same point (see detail).</li> <li>• Tighten lock nut.</li> </ul> <p><b>IMPORTANT</b> Monitor the winding operation until next ejection process. If the bobbins are not ejected press reset button.</p>

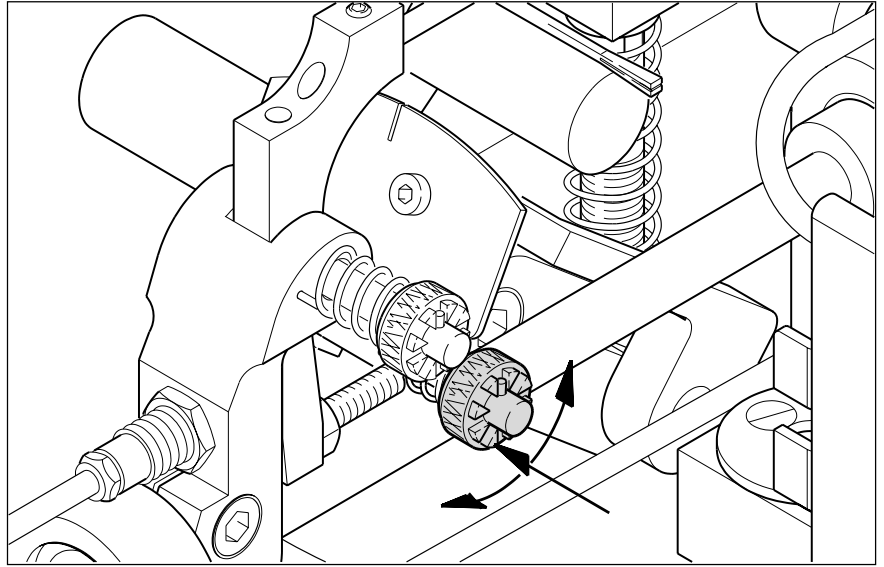

Fig. 10) Adjusting tucker plate

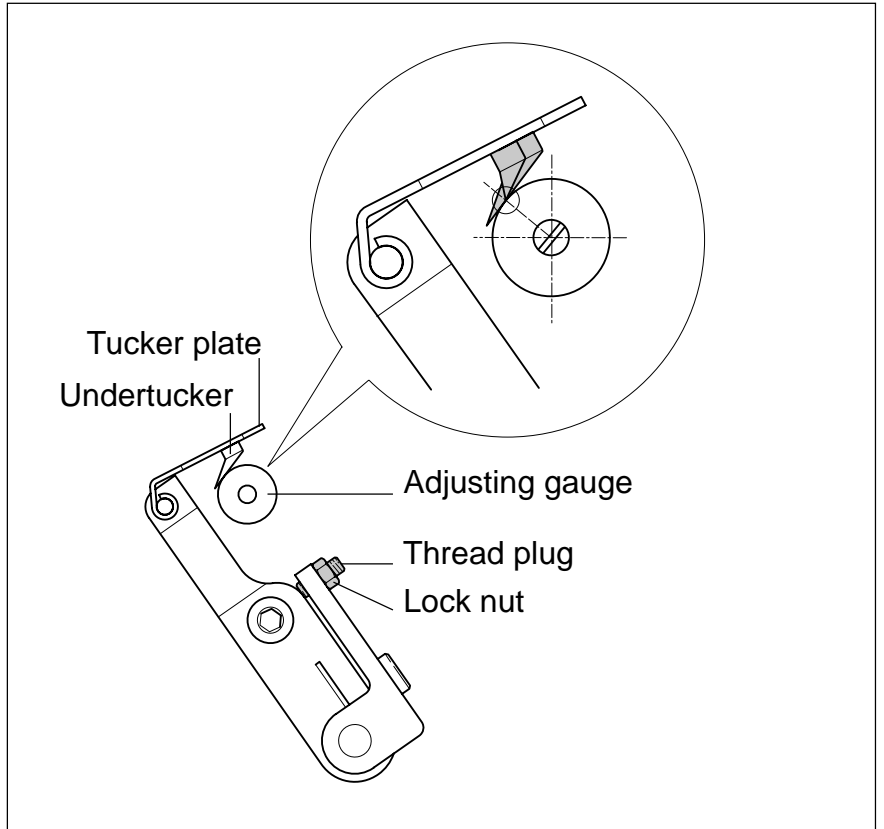

Fig. 11) Adjusting undertucker



Problem	Possible cause(s)	Remedy
13 Bobbin is damaged on being undertucked.	Tucker plate pressure too high.	<ul style="list-style-type: none"> <li>• Press in spring setting ring and turn clockwise (fig. 10).</li> </ul>
	Undertucker touches bobbin during ejection.	<p>Lift undertucker (fig. 12):</p> <ul style="list-style-type: none"> <li>• Check distance of undertucker with a suitable adjusting gauge.</li> </ul> <p>Find adjusting gauges with outer diameter of normal bobbins in the regulation kit.</p> <ul style="list-style-type: none"> <li>• Undo lock nut.</li> <li>• Turn thread plug with Allen key until the undertucker does not touch the bobbin any more.</li> <li>• Tighten lock nut.</li> </ul>
14 Thread is torn when undertucking.	Undertucker damages thread.	<ul style="list-style-type: none"> <li>• Smoothen the undertucker.</li> </ul>
	Thread inlet in the tucker plate has a sharp edge.	<ul style="list-style-type: none"> <li>• Smoothen the thread inlet.</li> </ul>



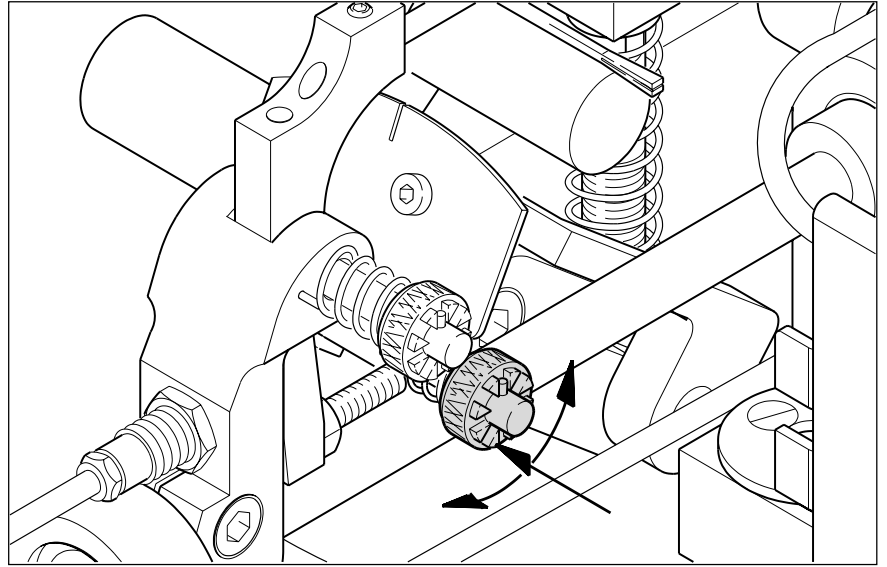

Fig. 10) Adjusting the tucker plate

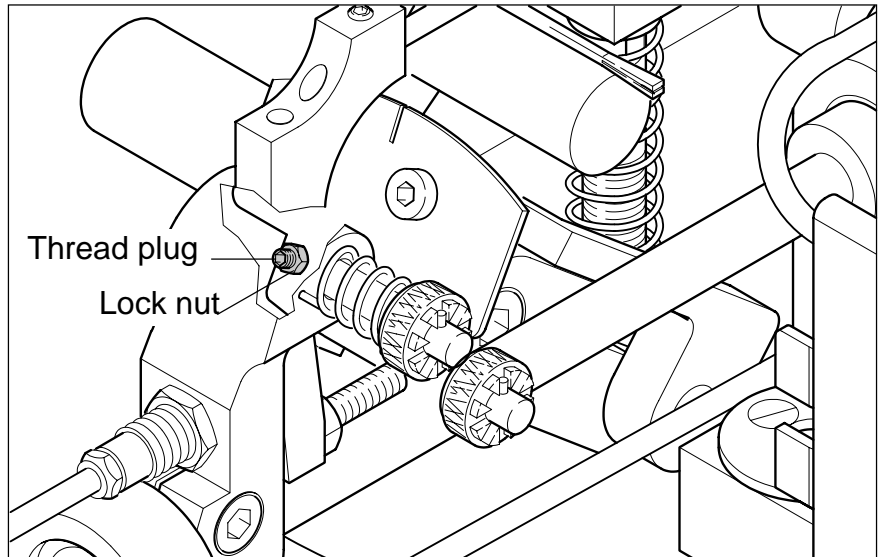

Fig. 12) Lifting the undertucker



Problem	Possible cause(s)	Remedy
15 Thread is torn after the bobbin has been ejected.	Ejection bolt has sharp or rough edges at the spherical end.	<ul style="list-style-type: none"> <li>• Polish the ejection bolt at the spherical end or replace.</li> </ul>
	Thread guide touches the tucker plate.	<p>Lift undertucker earlier (fig. 13):</p> <ul style="list-style-type: none"> <li>• Disconnect bobbin winding machine completely from mains.</li> <li>• Remove plastic cover: Undo both mounting screws on top side of housing. Only loosen all four mounting screws on side of housing. Tilt cover backwards 1-2 cm and lift subsequently.</li> <li>• Loosen clamping screw at switching lever.</li> <li>• Turn switching lever 0.5mm into direction roll lever valve and fix.</li> <li>• Install plastic cover and fix.</li> </ul>
16 Bobbin is thrown away by the scissors.	Bobbin does not fall into chute.	<p>Shift scissors (fig. 14):</p> <ul style="list-style-type: none"> <li>• Undo fixing screw at underside of housing.</li> <li>• Shift scissors into direction of spindle so that the bobbin falls correctly into the chute.</li> <li>• Tighten fixing screw again.</li> </ul>

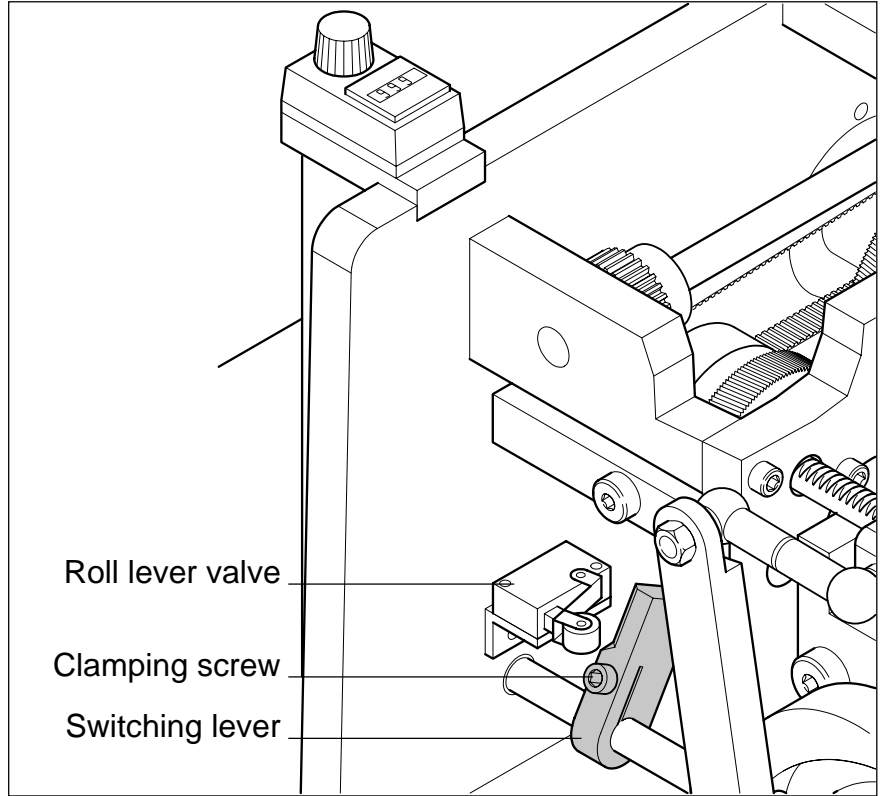

Fig. 13) Lifting the undertucker earlier

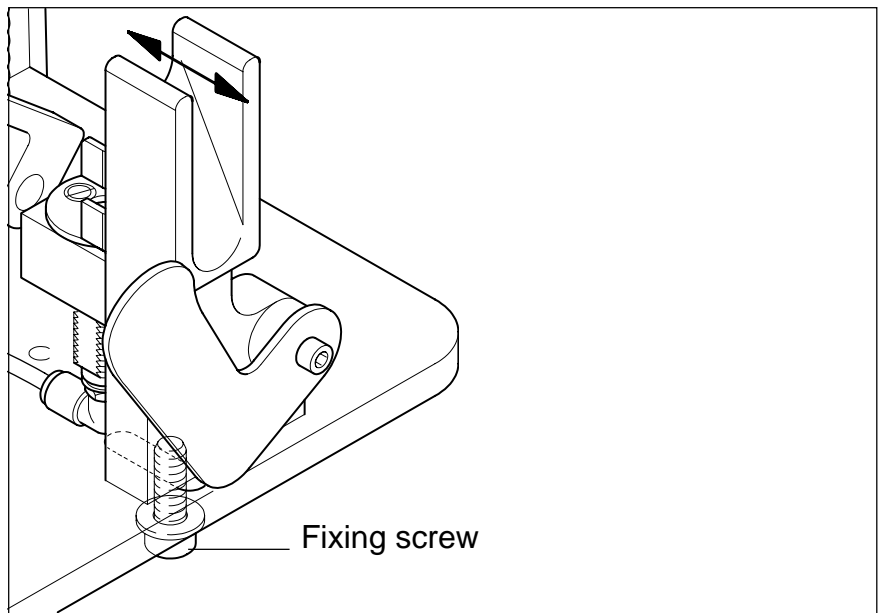
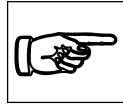

Fig. 14) Shifting the scissors



## 8. Maintenance



The bobbin winding machine has a low-maintenance drive. Meeting the required lubrication intervals is a pre-condition for uninterrupted operation and a long service life.



### CAUTION

Danger of injuries during maintenance works.

### Precautions

 All maintenance work on the bobbin winding machine may only be carried out at **stand still**.

 Before opening the housing always pull mains plug.

### 8.1 Cleaning

**Once daily** Remove the rubbed-off fibre and residue from the yarn from the winding heads and thread guide elements.

**Once annually** Clean the complete bobbin winding machine thoroughly.

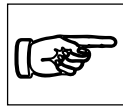

Casati Carlo AG recommends using an extraction unit if winding yarns produces excessive rubbed off fibres.

### 8.2 Lubricating instructions

**Once daily** Lubricate ball-and-socket joint of eccentric.

**Once annually** Remove cover. After cleaning of drive, cam plate and worm apply grease using a brush (about 2 brushstrokes).

### 8.3 Specification for lubricants

Lubricating oil ..... e.g. HLP10, branded hydraulic oil with a kinematic viscosity of 10 cSt (10 mm<sup>2</sup>/s)



If oil of this quality is not available, mix in high-pressure additive (T4) to a good spindle oil.

Grease ..... e.g. T4 white grease, highly adhesive grease with lithium soap base or a textile machine grease according to DIN 51 502.

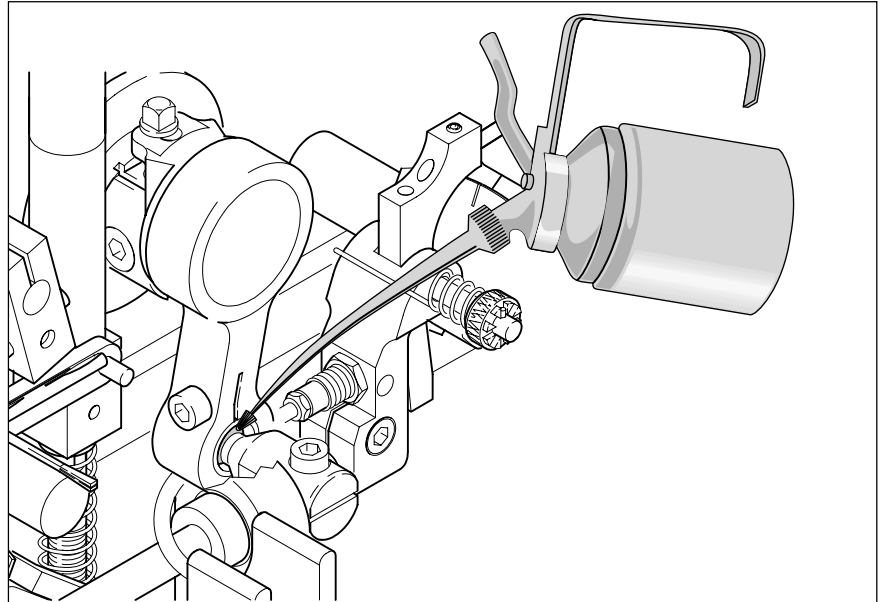

*Lubricating ball-and-socket joint*

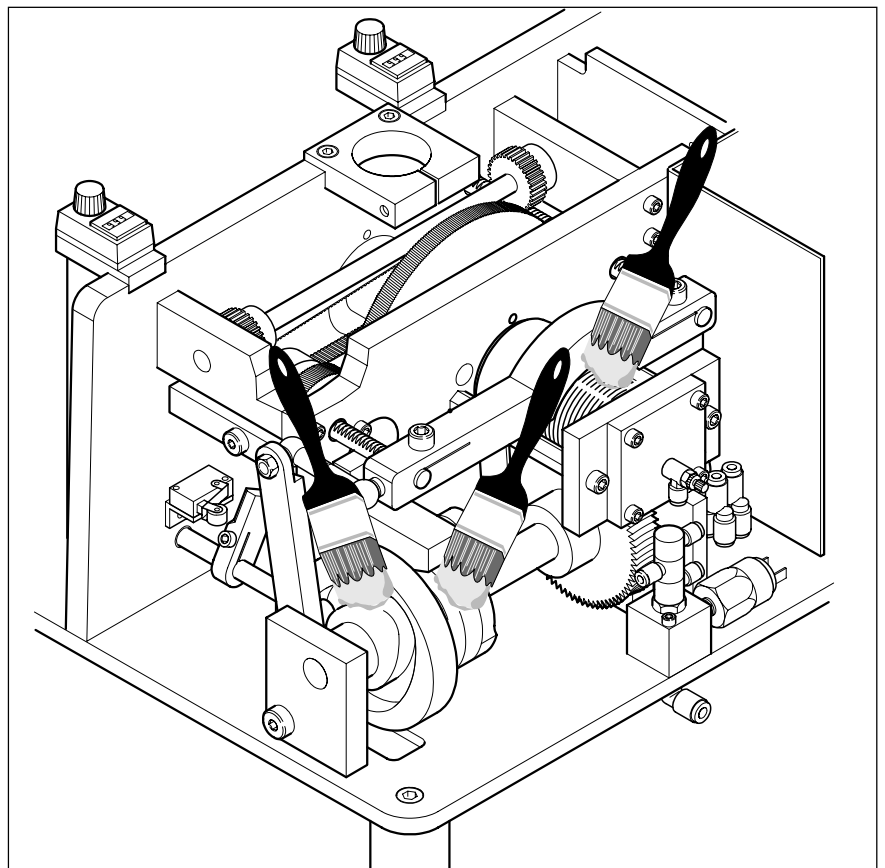

*Lubricating cam plates and worm*



## 9. Repair



All repair work may only be carried out by qualified personnel in order to detect and avoid occurring dangers.

### 9.1 Replacing instrument fuse

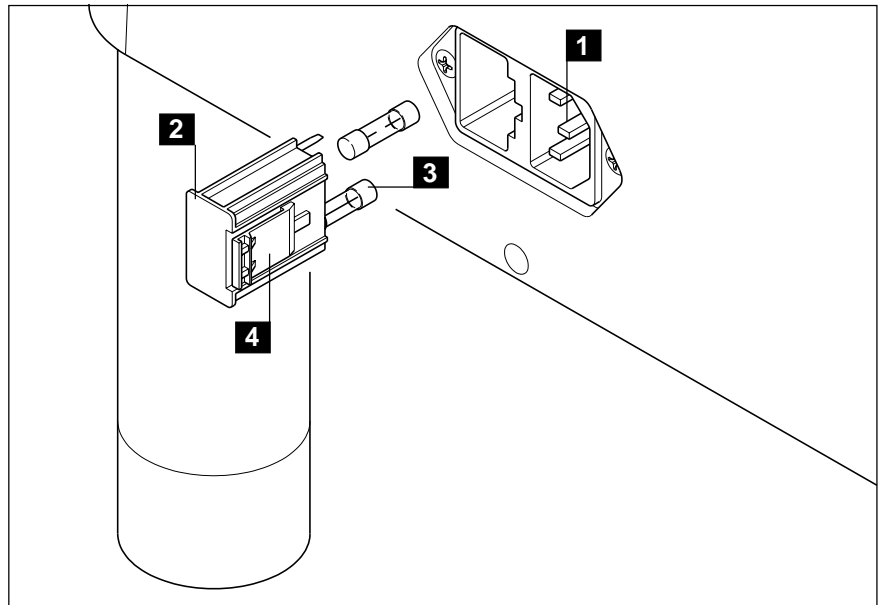





*Replacing instrument fuse*

1 Built-in plug  
2 Fuse insert

3 Spare fuse  
4 Locking part

#### Procedure

-  Unplug mains cable from built-in plug (1).
-  Unlock locking part (4) using a suitable screwdriver and pull out fuse insert (2).
-  Remove blown fuse and replace with spare fuse (3).
-  Insert fuse insert into built-in plug again and connect mains cable.

Permissible spare fuse for replacing fuse again:

Safety fuse with small breaking capacity: 4.0 A sluggish, dia. 5 x 20 mm.



## 9.2 Pneumatic diagram

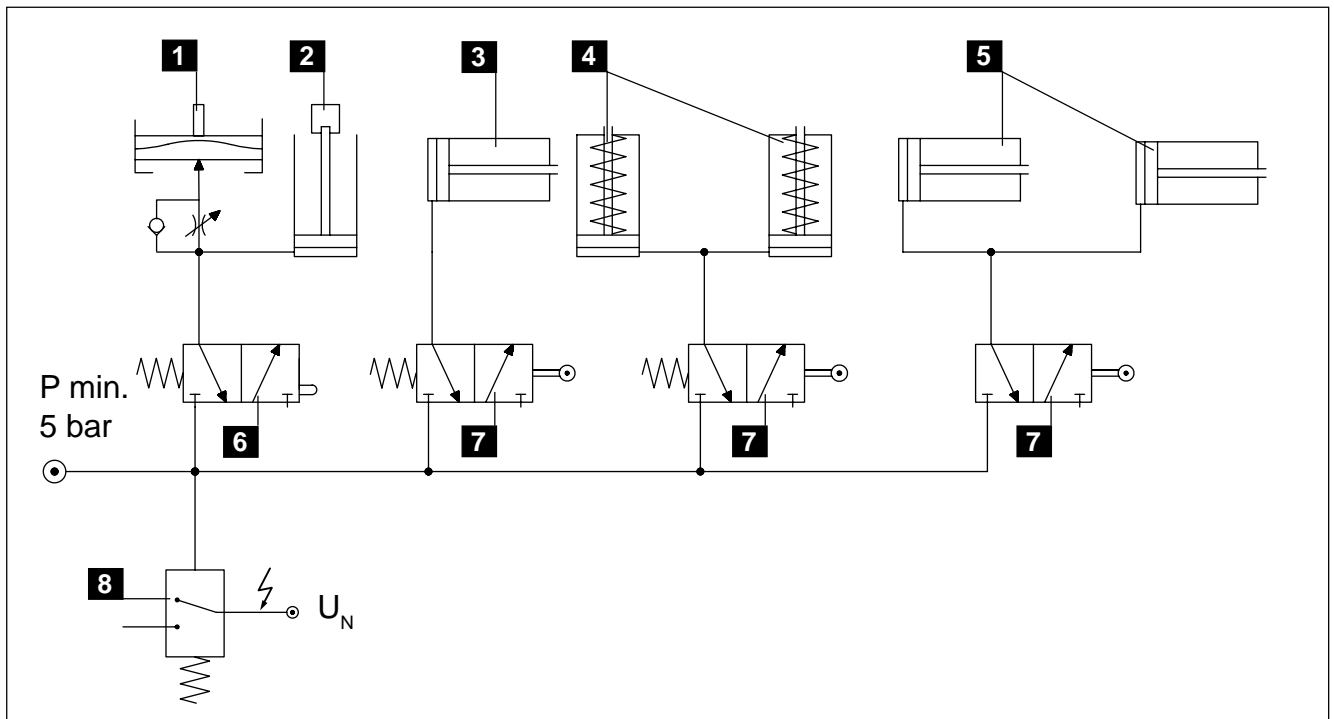

- 1 Pneumatically activated clutch
- 2 Pneumatic cylinder for lowering the bobbin tables
- 3 Resetting cylinder of diameter opening
- 4 Pneumatic cylinder for activating the scissors
- 5 Pneumatic cylinder for lifting the thread guide
- 6 Control valve with ram
- 7 Control valve with roll lever
- 8 Manostat



9.3 Wiring diagram

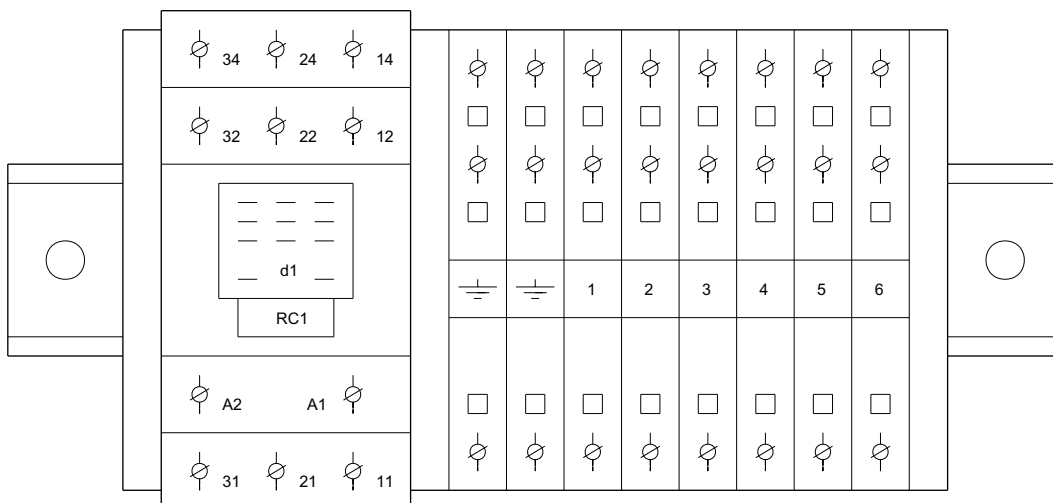
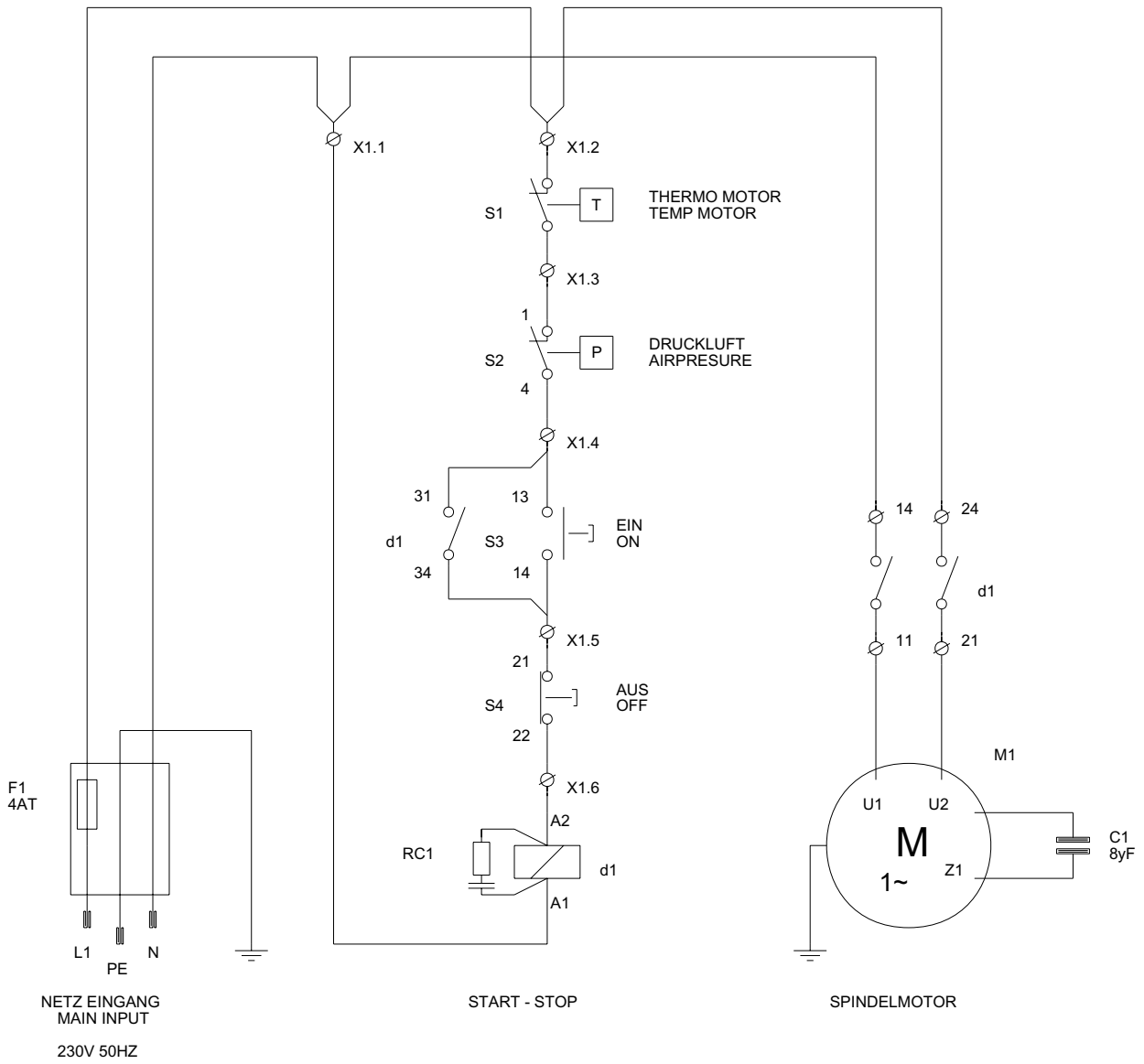







## 10. Waste disposal

The bobbin winding machine can be disposed of without the need to take special precautions.

Please take account of the following points:

-  Observe all national regulations concerning waste disposal.
-  Deliver the bobbin winding machine to Casati Carlo AG for proper recycling or to a waste disposal company.



### CAUTION

When taking the bobbin winding machine apart, injury can be caused by sprung machine parts (couplings etc.).





# Machine data sheet ECCO

**Machine number**

**Mains connection**

Single-phase, with protective conductor: L1, N, PE

Mains voltage: \_\_\_\_\_ VAC ( $\pm 10\%$ )

Mains frequency: \_\_\_\_\_ Hz

Installed load: 180 VA

**Compressed air connection**

Operating pressure: 5 - 7 bar (min./max.)

Consumption: approx. 2 - 4 dm<sup>3</sup>/h

**Direction of rot. of eccentric**

Left

Right

**Speed level**

1600 rpm

**Spindle**

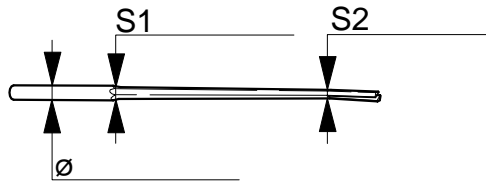

Cross section:



Art. No. \_\_\_\_\_

**Thread guides**

Casati Carlo

Ceramic

**Bobbin tables**

Roller

Slide

**Spring of bobbin tables**

Normal

Light

**Accessories fitted**

Oiling device

Extraction unit

Worktable

**Modifications / remarks**

\_\_\_\_\_  
\_\_\_\_\_  
\_\_\_\_\_

**Basic setting**

Refer to extra sheet "Machine settings"

Au, \_\_\_\_\_

Date

Signature





## Machine settings ECCO

Machine No.				
Shuttle No.				
Dimensions of bobbin L x $\varnothing$ (mm)				
Material				
Weight (g)				
Eccentric stroke (mm)				
Diameter setting				
Setting of bobbin table left				
Setting of bobbin table right				
Height of thread guide, left (mm)				
Height of thread guide, right (mm)				
Spring setting left (mm)				
Spring setting right (mm)				
Pretension of left inlet brake (cN)				
Pretension of right inlet brake (cN)				
Compensator setting left (1 - 9)				
Compensator setting right (1 - 9)				





## Machine settings ECCO

Machine No.				
Shuttle No.				
Dimensions of bobbin L x $\varnothing$ (mm)				
Material				
Weight (g)				
Eccentric stroke (mm)				
Diameter setting				
Setting of bobbin table left				
Setting of bobbin table right				
Height of thread guide, left (mm)				
Height of thread guide, right (mm)				
Spring setting left (mm)				
Spring setting right (mm)				
Pretension of left inlet brake (cN)				
Pretension of right inlet brake (cN)				
Compensator setting left (1 - 9)				
Compensator setting right (1 - 9)				







## Machine settings ECCO

Machine No.				
Shuttle No.				
Dimensions of bobbin L x $\varnothing$ (mm)				
Material				
Weight (g)				
Eccentric stroke (mm)				
Diameter setting				
Setting of bobbin table left				
Setting of bobbin table right				
Height of thread guide, left (mm)				
Height of thread guide, right (mm)				
Spring setting left (mm)				
Spring setting right (mm)				
Pretension of left inlet brake (cN)				
Pretension of right inlet brake (cN)				
Compensator setting left (1 - 9)				
Compensator setting right (1 - 9)				





## Machine settings ECCO

Machine No.				
Shuttle No.				
Dimensions of bobbin L x $\varnothing$ (mm)				
Material				
Weight (g)				
Eccentric stroke (mm)				
Diameter setting				
Setting of bobbin table left				
Setting of bobbin table right				
Height of thread guide, left (mm)				
Height of thread guide, right (mm)				
Spring setting left (mm)				
Spring setting right (mm)				
Pretension of left inlet brake (cN)				
Pretension of right inlet brake (cN)				
Compensator setting left (1 - 9)				
Compensator setting right (1 - 9)				





## Machine settings ECCO

Machine No.				
Shuttle No.				
Dimensions of bobbin L x $\varnothing$ (mm)				
Material				
Weight (g)				
Eccentric stroke (mm)				
Diameter setting				
Setting of bobbin table left				
Setting of bobbin table right				
Height of thread guide, left (mm)				
Height of thread guide, right (mm)				
Spring setting left (mm)				
Spring setting right (mm)				
Pretension of left inlet brake (cN)				
Pretension of right inlet brake (cN)				
Compensator setting left (1 - 9)				
Compensator setting right (1 - 9)				







**Fax: +41 / 71 744 56 24**





# EU Declaration of conformity



**CASATI CARLO AG  
Maschinenfabrik  
Industriestrasse 5  
CH-8434 Au / SG  
Switzerland**

We hereby declare that for the bobbin winding machine(s) with the machine no.

all essential safety requirements of the following EU directives apply:

- 98/37/EWG**      **Directive ,Machines‘, appendix II A**
- 89/336/EWG**    **EMC directive**
- 73/23/EWG**      **Low voltage directive**

Standards applied for assessing the bobbin winding machine:

- EN 292-1/2**      **Safety of machines, equipment and plants**
- EN ISO 11111**    **Safety requirements for textile machinery**
- EN 50 081-2**    **EMC, generic emission standard /  
industrial environment**
- EN 50 082-2**    **EMC, generic immunity standard /  
industrial environment**
- EN 60 204-1**    **Electrical equipment of machines**

Au, \_\_\_\_\_

Place and date of issue

Description of signatory

Signature

